

CONTENTS

INTRODUCTION

3 SIGNIFICANCE of ceramics for kiln construction and furniture

MATERIALS

4-5 SUMMARY of our ceramic materials

6-7 INSULATION COMPOUNDS

8 REFRACTORY CEMENTS

9 Physical PROPERTIES

DESIGNING

10 CERAMIC TUBES Selection from our production programme

11 TOLERANCES according to DIN 40680

APPLICATION

12-13 EXAMPLES OF APPLICATIONS for ceramic materials

14-15 CERAMIC ROLLERS

16-17 EXAMPLES OF APPLICATIONS for ceramic components

18 SIZES of muffles, open both ends

SOLUTIONS

19 TECHNICAL CERAMICS

Optimised utilisation of energy: The short thermal cycle of the roller hearth kiln.

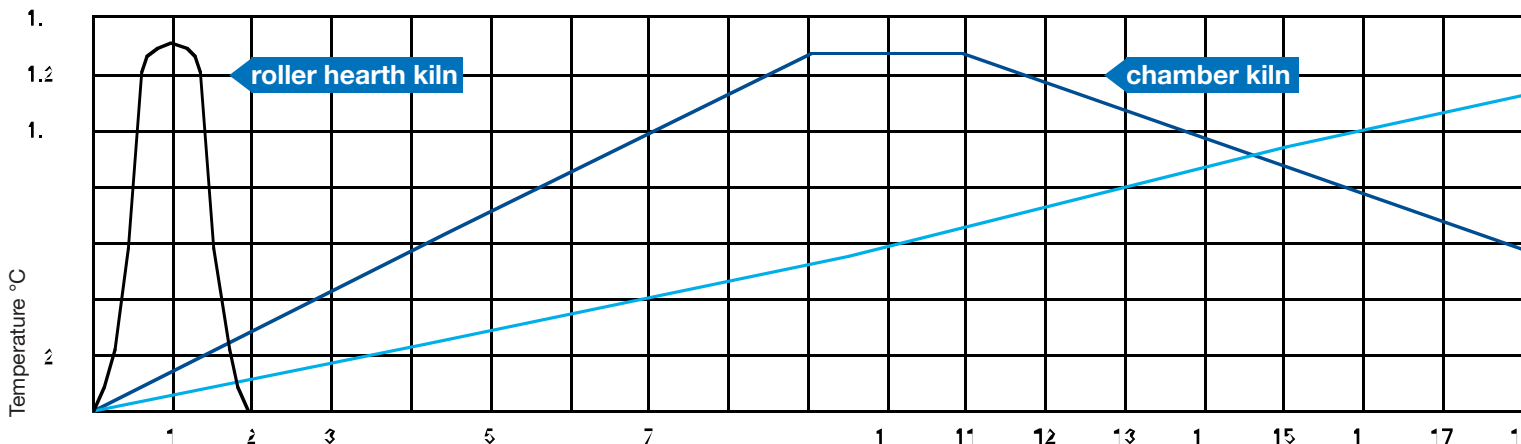

SIGNIFICANCE

of ceramics for kiln construction and furniture

Heat treatment is an important process step in research and industry. Heat treatment is also linked to energy consumption. Energy is an essential and valuable commodity and will always continue to appreciate in value. For this reason, and also to support the need for reducing energy consumption, furnace design and construction has undergone fundamental changes in recent years and these changes will continue. Success in achieving these changes has been mainly attributed to the use of structural ceramic components and optimised ceramic materials which have replaced traditional metal parts.

HALDENWANGER is the producer of high temperature, fine ceramics.

HALDENWANGER fine ceramics offer:

- Components with reduced wall thickness and therefore lower heat absorption
- Components having higher thermal shock resistance allowing increased heating rates
- Light, but mechanically strong and thermally stable kiln furniture, which is suitable for fast firing
- Thin, self-supporting designs

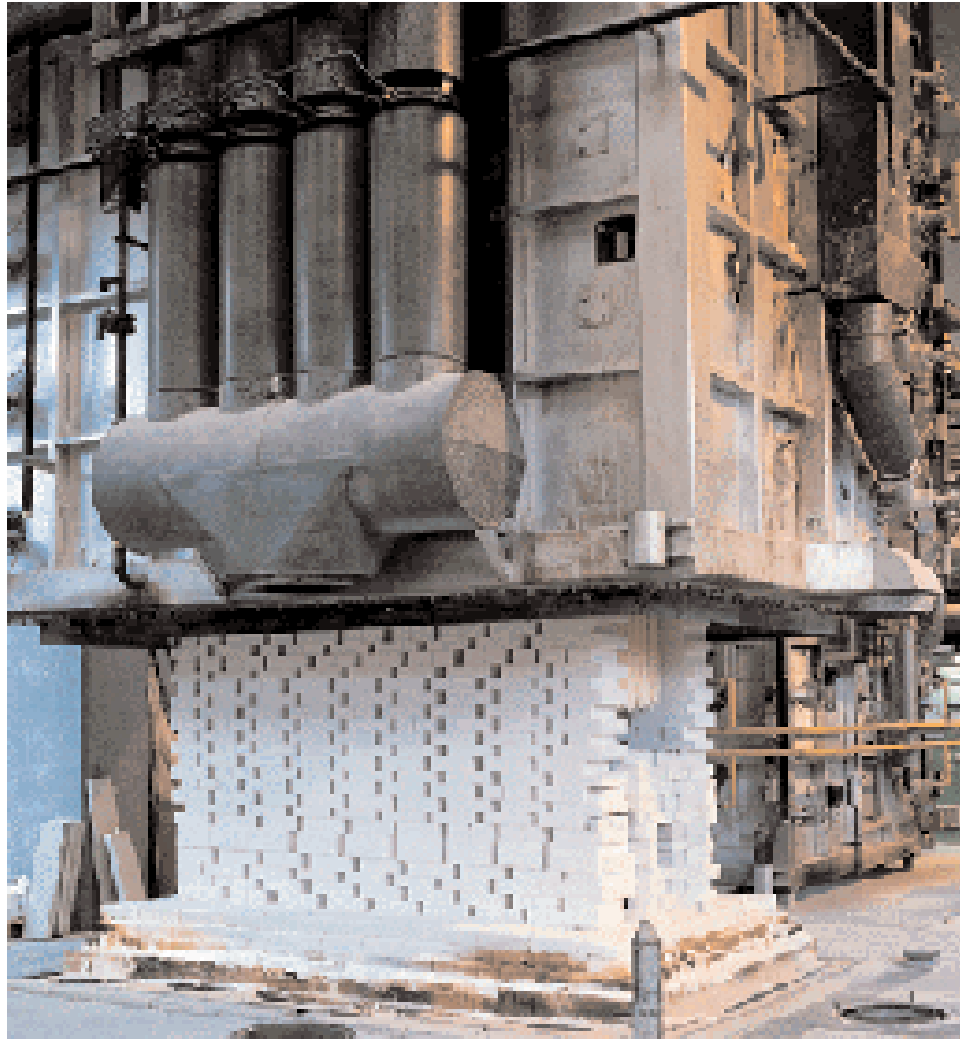

Intermittent Kiln

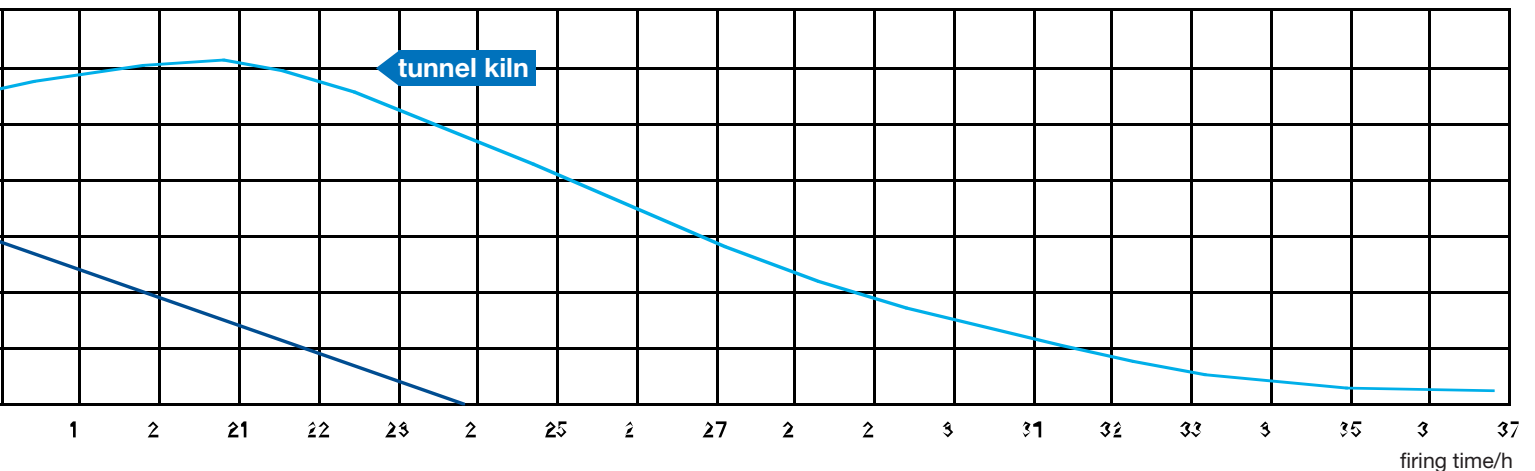

SUMMARY

of our ceramic materials

IMPERVIOUS MATERIALS

Alsint 99,7

Best, high temperature, ceramic material for kiln construction with 99,7% Al_2O_3 (the difference is mainly MgO and SiO_2).

- Type C 799 according to DIN VDE 0335
- Refractoriness up to 1700 °C
- Good thermal shock resistance due to high thermal conductivity
- High mechanical strength
- High electrical resistivity

Recommended applications:

- High working temperature, chemical attack, e.g. hydrogen and other reducing gases
- Clean kiln atmosphere
- Thin-walled designs having high thermal shock resistance

Pythagoras 1800 Z

Impervious, mullite high performance material

- Refractoriness up to 1600 °C
- Very high thermal shock resistance
- High mechanical strength
- High electrical insulation even at high temperatures
- Evaporation extremely low, therefore no contamination of kiln atmosphere; no reaction with heating element
- Most suitable material for radiant heating tubes
- Kiln tubes made of Pythagoras 1800 Z can be very thin-walled

Pythagoras

Most economical, mullite material for kiln components

- Type 610 according to DIN VDE 0335
- Application temperatures up to 1400 °C
- Very good chemical resistance against gases free of fluorine
- For kiln working under normal conditions Pythagoras has a good thermal shock resistance and good mechanical strength.
- Pythagoras is a very economical material being used as impervious protection sheaths and insulators for temperature measurement.

Halsic-I

Silicon infiltrated reaction bonded silicon carbide (SiSiC)

- Reaction bonded SiC matrix, free of pores, with residual metallic silicon
- High temperature ceramics for highest mechanical loads
- Extremely good oxidation resistance
- Large sized components possible
- Application temperatures up to 1350 °C
- Corrosion resistant against strong acids and alkaline solutions
- High thermal conductivity

Halsic-S

Pressureless sintered silicon carbide (SSiC)

- Dense sintered SiC matrix with very low percentage of closed pores
- High temperature ceramics for extreme mechanical loads
- Extremely good oxidation resistance
- Application temperatures up to 1600 °C
- Corrosion resistant against strong acids and alkaline solutions

POROUS MATERIALS

Alsint porous

High purity, porous 99,5% Al_2O_3

- Better thermal shock resistance than Alsint 99,7
- Refractoriness is similar to Alsint 99,7
- Similar chemical resistance to Alsint 99,7
- Reducing gases, even pure hydrogen, do not attack Alsint porous.
- Alsint porous is mainly used for the manufacture of ignition dishes and crucibles, but also for porous outer protection tubes for thermocouples. Isostatic pressing is possible, so that large tubes can also be manufactured.
- Muffle tubes

SKA 100 NG

High purity, porous 99,5% Al_2O_3

- Refractoriness up to 1700 °C
- High thermal shock resistance
- Good chemical resistance
- SKA 100 NG can be used in protection furnaces with reducing or even hydrogen atmospheres.

SKA 100 NG as well as Alsint:

- Does not react with the heating elements, no contamination of the kiln atmosphere due to evaporation.
- Is most suitable for the porous, outer protection tube for thermocouples that must withstand very strong chemical attacks.

Sillimantin 60 NG

A specially developed material for use in kiln manufacture having an Al_2O_3 content between 73 – 75%.

- Low porosity
- Good thermal shock resistance
- No reactions with the heating elements
- Working temperatures of up to 1650 °C
- Special shapes possible for bridging long distances between supports
- Excellent chemical resistance. No contamination of the kiln atmosphere through evaporation.
- Suitable for kilns with a high temperature gradient
- Sillimantin 60 NG can be used under severe conditions as the outer protective tube in temperature monitoring devices.
- Rollers for roller kilns

Sillimantin 60

Most frequently used ceramic material in kiln designs

- Type C530 according to DIN VDE 0335
- Application temperatures up to 1400 °C
- Refractoriness up to 1300 °C (subject to loading for roller applications)
- No reactions with heating elements
- This material can be formed using most moulding methods.
- Numerous special designs are possible as well as a wide range of standard tubes
- This material is used successfully in laboratory and industrial kilns.

Sillimantin 65

A specially developed material for use as rollers having an Al_2O_3 content between 78 – 80%

- Refractoriness up to 1350 °C (subject to operational loading)
- Negligible reaction with glazes because of fine porosity
- Roller materials are detailed on page 14

Sillimantin KS

Most economical for support tubes

- Refractoriness up to 1300 °C
- Good mechanical strength
- Large scale production with emphasis on the most commonly used diameters permitting economical manufacture.
- A stock list of standard sizes is given on page 10.

SiC

Conventional, clay-bonded silicon carbide

- Excellent thermal conductivity allows the manufacture of thick-walled components having high mechanical strength.
- Furnace tubes with high thermal shock resistance
- Can be used in oxidising atmospheres up to 1400 °C
- High mechanical strength because of a large wall thickness
- Sighting tubes for optical temperature measurement
- Outer protection tubes for temperature measurement up to 1200 °C in light and heavy metal smelts

Fused Silica

99,8% SiO_2

- Very low thermal expansion
- Excellent thermal shock resistance
- Can be used continuously at temperatures up to 1000 °C

This material is used for:

- Rollers in glass tempering furnaces
- Crucibles in high-frequency melting
- Riser tubes for continuous casting
- Crucibles withstanding high thermal shock

Halsic-R

Recrystallised silicon carbide (RSiC)

- Compact SiC matrix with open porosity
- Classic ceramic for high temperature applications
- Large sized components possible
- Reliable bonding of coatings
- Application temperatures: 1600 °C (oxidising) and approx. 2000 °C (under protective atmosphere)
- Resistant against strong acids and alkaline solutions

Halsic-RX

Chemically doped recrystallised silicon carbide (RSiC_{doped}).

- Compact SiC matrix with open porosity
- Very good oxidation resistance
- Multiple increased life time compared to Halsic-R
- Ideal material for porcelain fast firing
- Large sized components possible
- Reliable bonding of coatings
- Application temperatures up to 1650 °C (oxidising)

INSULATION COMPOUNDS

Insulation compounds are used for embedding or fixing electric heating elements on ceramic parts. An exception is the compound SKA 90 (see right column).

Insulation compounds are used for filling gaps and cracks as well as for kiln repair. Firing supports can also be manufactured from these compounds. The compounds are prepared by adding water to the powder and set by heating. Final strength is achieved by heating to the required temperature indicated in the table on page 7.

Shrinkage is minimal using this process. HALDENWANGER insulation compounds are free from electrolytes to ensure good electrical insulation even at extremely high temperatures.

1 Preparation instructions and use of insulation compounds

The powder is mixed thoroughly with water which is free from electrolytes. For good processability the paste should not stick to the back of one's hand. After embedding, the insulation material should be left for about 24 hours to dry at approx. 50 °C. The material can then be shaped, filed or drilled.

Final strength of the insulation material is achieved by heating it to the required temperature. It is recommended to surround the kiln tube with a layer of insulation during this heat treatment.

Heating for the first time should be done with care. Initial blackening of the compounds 1000 and 1000 F during heating is due to carbonisation of the organic binder and will disappear after soaking temperature is reached.

If too much powder is mixed, the remainder can be dried and used again. Contamination may, however, render the insulation compounds unusable.

2 Information about kiln design

The electric heating coils must be evenly spaced and checked by means of a gauge prior to embedding.

For kilns heated with nickel-chrome elements, i.e. for temperatures exceeding 1000 °C, grid voltage is not recommended.

The heating coils will last longer if the voltage is 110 V or less. If possible, the insulation compound should be prepared using water free of electrolytes.

Because of its ion content, normal tap water reduces the electrical resistivity of the insulation substances. This should be taken into consideration if furnaces for high temperatures are involved.

If the powders are mixed frequently, water totally free of electrolytes must be used.

Insulation Compound 150

Our compound 150 is used for embedding heating wires having diameters of approximately 1 – 3 mm.

Due to its composition the compound can be used up to a temperature of approx. 1350 °C. The setting temperature is 1000 °C. Please refer to "Insulation Compounds" for more preparation details.

Insulation Compounds 60 – 1000 F

For fixing heating wires having a diameter of 1 mm or more, we recommend the use of compound 60 at temperatures not exceeding 1350 °C and compound 1000 for temperatures up to 1800 °C. Heating wires with a diameter of less than 1 mm should be embedded with compound 250 at temperatures up to 1350 °C and with compound 1000 F for temperatures up to 1800 °C.

Insulation Compound SKA 90

This substance was tailored to withstand slag attack. It is used for crucible linings in which precious metals are melted. Without such linings contamination of molten metals may occur. Besides excellent corrosion resistance this compound also has an extremely good thermal shock resistance.

Available Insulation Compounds

| Isolations mix no. | Refractoriness Seeger cone small at 150 °C/h heatingrate | Setting temperature | Guide analysis | | Grain size distr. | | Max. temperature |
|--|---|------------------------|---|--|-------------------|---------|---------------------|
| | | | | | µm | % | |
| 60 coarse grain structure | SK 38 = 1825 °C | 1000 °C | Al ₂ O ₃ 90,50 % SiO ₂ 9,00 % | > 355 4,80 > 200 78,60 > 100 92,70 > 90 94,10 < 90 5,90 | | 1350 °C | |
| 150 medium grain structure | SK 38 = 1825 °C | 1000 °C | Al ₂ O ₃ 90,50 % SiO ₂ 9,00 % | > 355 7,30 > 200 11,80 > 100 49,40 > 90 63,50 < 90 36,50 | | 1350 °C | |
| 250 fine grain structure | SK 38 = 1825 °C | 1000 °C | Al ₂ O ₃ 90,50 % SiO ₂ 9,00 % | > 355 6,50 > 200 10,00 > 100 15,00 > 90 23,20 < 90 76,80 | | 1350 °C | |
| 1000 coarse grain structure | SK 42 = 2000 °C | 1300 °C | Al ₂ O ₃ 99,70 % SiO ₂ 0,01 % | > 355 37,50 > 200 71,00 > 100 87,60 > 90 92,70 < 90 7,30 | | 1800 °C | |
| 1000 F fine grain structure | SK 42 = 2000 °C | 1300 °C | Al ₂ O ₃ 99,70 % SiO ₂ 0,01 % | > 355 0,25 > 200 2,25 > 100 36,55 > 90 54,15 < 90 45,85 | | 1800 °C | |
| SKA 90 | SK 38 = 1825 °C | | Al ₂ O ₃ 95,00 % SiO ₂ 4,75 % | > 355 40,10 > 200 81,20 > 100 93,40 > 90 94,50 < 90 5,50 | | 1750 °C | |

REFRACTORY CEMENTS

Important:

- Cements are not insulating compounds
- Cements are not suitable for fixing any kind of heating wire
- Cements are not to be used in furnace construction.

WH Refractory Cement 1500

Directions for use

WH refractory cement is an inorganic adhesive which is resistant to temperatures of more than 1500 °C.

The surfaces to be joined together must be carefully cleaned of dirt, grease and oil. Remove all traces of the chemicals used for cleaning (petrol, acetone, soap powder) before applying the WH refractory cement. The faces must be completely dry.

Depending on the consistency required, the cement should be mixed homogeneously using 2–4 parts powder to one part liquid.

Apply a layer on each of the surfaces to be stuck together. The cement sets by chemical reaction and should be used within approx. 1 hour. Good mechanical strength of the refractory cement is obtained after about 24 to 36 hours at room temperature. Drying at higher temperatures will accelerate the hardening process and improve the mechanical strength.

The mechanical strength of the WH refractory cement as a function of drying temperature was verified in tests.

Square-sectioned rods of Sillimantín 60 were cemented together at defined faces and heated to a temperature of approx. 1500 °C. The cemented areas of the two pieces were then stressed at room temperature until fracture occurred. The relation between mechanical strength and firing temperature proved to be linear.

WH Refractory Cement 1800

This cement is mainly used for joining pieces operating at high temperatures of at least 1700 °C.

It is supplied as a single-component system ready to use and after drying for approx. 24 hours at 100 °C the cement has a certain strength. The strength is reduced as the temperature increases up to approx. 800 °C.

Above 800 °C the strength increases continuously and reaches its highest value at 1800 °C.

Refractory cement 1800 should be kept closed at all times. A thin film of hardened cement may have to be removed before use.

WH Refractory Cement 1300/1800

This cement is also supplied ready for use. It can be applied in the same fields as refractory cement 1800. However, its strength increases continuously with rising temperature. There is no reduction in strength up to 800 °C as described for refractory cement 1800. It must be pointed out that this cement is hygroscopic. Furthermore, it can have a corrosive effect on metals. Therefore, it is not suitable for embedding metal parts or heating elements.

WH Refractory Cement 98

This cement is supplied as a single-component system. It must be prepared to a pulpy consistency by adding water and is then ready for application. The cement should be used within approx. 1 hour before setting starts. Compared to refractory cement 1500, this cement has the advantage of being suitable for temperatures up to 1700 °C. Shrinkage during firing is very low (approx. 2%).

Under certain conditions refractory cement 98 can be used as an electrical insulator.

- WH refractory compound WH 98.



Physical PROPERTIES

| | Unit | Impervious Materials | | | | | Porous Materials | | | | | | | | | |
|--|---|----------------------|-------------------|-------------------|-----------------------|-----------------------|----------------------|-------------------|----------------|----------------|----------------|---------------------------------|---------------------|--|--|--|
| | | Alsint 99,7 | Pythagoras 1800 Z | Pythagoras | Halsic-I | Halsic-S | Alsint porous | Sillimantin 60 NG | Sillimantin 60 | Sillimantin 65 | Sillimantin KS | SiC (clay bonded) ¹⁾ | Quartzgut | Halsic-R | Halsic-RX | |
| Al ₂ O ₃ content | % | 99,7 | 76 | 60 | - | - | 99,5 | 72-74 | 72-74 | 78-80 | 70 | - | - | - | - | |
| Alkali content | % | - | 0,5 | 3,0 | - | - | - | ≤ 1 | ≤ 1 | ≤ 1 | ≤ 1 | - | - | - | - | |
| SiC content | % | - | - | - | 88-92 | ≥ 99 | - | - | - | - | - | 70-90 | - | > 99 | > 99 | |
| Si content (free) | % | - | - | - | 8-12 | ≤ 0,1 | - | - | - | - | - | - | - | ≤ 0,1 | ≤ 0,1 | |
| Type acc. to DIN VDE 0335 | - | 799 | - | 610 | - | - | - | - | 530 | - | - | - | - | - | - | |
| Water absorption | % | ≤ 0,2 | ≤ 0,2 | ≤ 0,2 | ≤ 0,1 | ≤ 0,1 | 2-7 | 6 | 9 | 11 | 9 | 8-13 | 4-6 | 5 | 5 | |
| Leakage rate at 20 °C | hPa · dm ³ · s ⁻¹ | 10 ⁻¹⁰ | - | 10 ⁻¹⁰ | - | - | - | - | - | - | - | - | - | - | - | |
| Density | g · cm ⁻³ | 3,75-3,94 | 3,0 | 2,6 | 3,1 | 3,1 | < 3,6 | 2,65 | 2,35 | 2,45 | 2,35 | 2,2-2,5 | 1,92-2,00 | 2,7 | 2,7 | |
| Flexural strength 20 °C (3-point) | MPa | 300 | 150 | 120 | 240-280 ²⁾ | 350-400 ²⁾ | 70-110 ²⁾ | 60 | 45 | 55 | 45 | 30 | 30-40 | 80-100 ²⁾ | 80-100 ²⁾ | |
| Flexural strength 1300 °C (3-point) | MPa | - | - | - | 250-300 | 370-420 ²⁾ | - | - | - | - | - | - | 45-60 ³⁾ | 90-110 | 90-110 | |
| Young's modulus | GPa | 300-380 | 150 | 100 | 370 | 420 | - | 85 | 60 | 75 | 60 | - | 30-40 | 280 | 280 | |
| Hardness (Mohs scale) | - | 9 | 8 | 8 | - | - | - | - | - | - | - | - | - | - | - | |
| Thermal expansion 20 - 700 °C | 10 ⁻⁶ · K ⁻¹ | 7,8 | 5,6 | 5,4 | 3,7 | 4,5 | 7,8 | 5,2 | 5,3 | 5,3 | 5,3 | 5 | - | 3,9 | 3,9 | |
| Thermal expansion 20 - 1000 °C | 10 ⁻⁶ · K ⁻¹ | 8,6 | 6,0 | 6,0 | 4,3 | 5,0 | 8,6 | 5,7 | 5,7 | 6,3 | 5,7 | 5 | 0,5-0,9 | 4,5 | 4,5 | |
| Thermal conductivity 20 - 100 °C | W · m ⁻¹ · K ⁻¹ | 25 | 6 | 2 | 100 | 124 | - | - | 1,4 | 1,4 | 1,4 | - | - | 35 | 35 | |
| Max. working temperature ⁴⁾ | °C | 1700 | 1600 | 1400 | 1350 ⁵⁾ | 1600 ⁵⁾ | 1700 | 1650 | 1350 | 1400 | 1350 | 1300 | 1000 | 1600 ⁵⁾ 2000 ⁶⁾ | 1650 ⁵⁾ 2000 ⁶⁾ | |
| Permissible continuous temperature for protection sheaths acc. to DIN 43724 | °C | 1600 | - | 1500 | - | - | - | - | 1600 | - | - | - | - | - | - | |
| Permissible continuous temperature for insulating rods sheaths acc. to DIN 43724 | °C | 1800 | - | 1500 | - | - | - | - | - | - | - | - | - | - | - | |
| Dielectric strength acc. to IEC 672-2 | kV · mm ⁻¹ | 26 | 26 | 26 | - | - | - | - | - | - | - | - | - | - | - | |
| Volume resistivity at D.C. 20 °C | Ω · cm | 10 ¹⁴ | 10 ¹³ | 10 ¹³ | - | - | - | - | - | - | - | - | - | - | - | |
| Thermal shock resistance | - | good | good | good | very good | very good | good | good | very good | very good | very good | very good | very good | very good | very good | |
| Pore size (average) | µm | - | - | - | - | - | 1-3 | 8,5 | 2 | 1,5 | 2 | 3 | ≤ 0,2 | 24 | 24 | |
| Specific heat capacity 20 - 100 °C | J kg ⁻¹ · K ⁻¹ | 900 | 900 | 900 | 900 | 1000 | - | 900 | 800 | 900 | - | - | - | - | - | |

The physical properties stated above result from test pieces. These values can only be used as a reference to other forms and dimensions depending on manufacturing process, geometry, surface finish and machining. In practice, e.g. Alsint 99,7 components have a flexural strength of between 160 and 340 MPa. ¹⁾ properties for general information only due to different qualities, ²⁾ 4-point bending strength, ³⁾ at 700 °C, ⁴⁾ depending on load, ⁵⁾ in oxidising atmosphere, ⁶⁾ in inert atmosphere.

CERAMIC TUBES

Selection of our production programme

| Impervious Materials | Alsint 99,7 | | | Pythagoras | | | Pythagoras 1800 Z |
|----------------------|--|-----------|-------------|---|-----------|-----------|--|
| | Type C799 (DIN VDE 0335) Al ₂ O ₃ content 99,7% | | | Type C610 (DIN VDE 0335) Al ₂ O ₃ content approx. 60% Alkali content 3% | | | Al ₂ O ₃ content approx. 76% Alkali content 0,33% |
| | Outer x inner Ø mm | | | Outer x inner Ø mm | | | Outer x inner Ø mm |
| 0,8 x 0,3 | 26 x 20 | 120 x 100 | 0,8 x 0,3 | 20 x 15 | 80 x 70 | 48 x 40 | |
| 1,3 x 0,7 | 28 x 22 | 120 x 105 | 1,3 x 0,7 | 22 x 17 | 85 x 75 | 53 x 43 | |
| 1,6 x 1,0 | 30 x 23 | 130 x 110 | 1,6 x 1,0 | 24 x 18 | 90 x 75 | 60 x 52 | |
| 1,8 x 1,2 | 35 x 27 | 140 x 120 | 1,8 x 1,2 | 24 x 19 | 90 x 80 | 63 x 53 | |
| 2,0 x 1,0 | 38 x 30 | 140 x 125 | 2,0 x 1,0 | 26 x 18 | 95 x 85 | 70 x 60 | |
| 2,7 x 1,7 | 42 x 34 | 150 x 130 | 2,7 x 1,7 | 26 x 20 | 100 x 85 | 73 x 63 | |
| 3,0 x 2,0 | 46 x 38 | 155 x 135 | 3,0 x 2,0 | 28 x 22 | 105 x 90 | 75 x 65 | |
| 4,0 x 2,0 | 50 x 40 | 160 x 140 | 4,0 x 2,0 | 30 x 23 | 110 x 95 | 80 x 70 | |
| 5,0 x 3,0 | 55 x 45 | 170 x 150 | 5,0 x 3,0 | 31 x 25 | 115 x 100 | 82 x 72 | |
| 6,0 x 4,0 | 60 x 50 | 175 x 155 | 6,0 x 4,0 | 35 x 27 | 120 x 100 | 85 x 74 | |
| 8,0 x 5,0 | 65 x 56 | 180 x 160 | 8,0 x 5,0 | 38 x 30 | 125 x 105 | 86 x 76 | |
| 9,0 x 6,0 | 70 x 60 | 185 x 165 | 9,0 x 6,0 | 40 x 32 | 130 x 110 | 87 x 77 | |
| 9,6 x 6,4 | 72 x 62 | 190 x 170 | 9,6 x 6,4 | 45 x 38 | 140 x 120 | 88 x 78 | |
| 10,0 x 6,0 | 75 x 65 | 200 x 175 | 10,0 x 6,0 | 48 x 40 | 140 x 125 | 93 x 83 | |
| 12,0 x 8,0 | 80 x 70 | 220 x 200 | 12,0 x 8,0 | 50 x 40 | 150 x 130 | 95 x 85 | |
| 12,7 x 8,9 | 85 x 75 | 240 x 220 | 12,7 x 8,9 | 52 x 42 | 160 x 140 | 100 x 90 | |
| 14,0 x 10,0 | 90 x 80 | 260 x 240 | 14,0 x 10,0 | 55 x 46 | 170 x 150 | 105 x 90 | |
| 15,0 x 10,0 | 95 x 85 | 270 x 250 | 15,0 x 10,0 | 58 x 50 | 180 x 160 | 115 x 105 | |
| 17,0 x 12,0 | 100 x 85 | 300 x 280 | 15,0 x 11,0 | 60 x 50 | 190 x 170 | 120 x 110 | |
| 17,5 x 11,1 | 105 x 90 | 320 x 300 | 17,0 x 12,0 | 65 x 55 | 200 x 180 | | |
| 20,0 x 15,0 | 110 x 95 | 420 x 380 | 17,0 x 13,0 | 70 x 60 | 240 x 220 | | |
| 24,0 x 18,0 | 115 x 100 | 450 x 430 | 17,5 x 11,1 | 75 x 65 | 300 x 280 | | |

| Porous Materials | Sillimantin 60 NG | Sillimantin 60 | Sillimantin KS | SKA 100 NG | Siliciumcarbid | Quarzgut |
|------------------|--|---|---|---|--|-------------------------------------|
| | medium fine structure Al ₂ O ₃ content approx. 73–75% | Type 530 (DIN VDE 0335) medium fine structure Al ₂ O ₃ content approx. 73–75% | medium fine structure Al ₂ O ₃ content approx. 70% | medium fine structure Al ₂ O ₃ content approx. 99,5% | fine and coarse structure SiC content 70% | especially for flat glass tempering |
| | Outer x inner Ø mm | Outer x inner Ø mm | Outer x inner Ø mm | Outer x inner Ø mm | Outer x inner Ø mm | Ø mm |
| 20 x 15 | 20 x 15 | 15 x 7 | 26 x 18 | 17 x 12 | 20 | |
| 22 x 17 | 22 x 17 | 20 x 12 | 28 x 22 | 20 x 15 | 25 | |
| 24 x 19 | 24 x 19 | 20 x 15 | 30 x 23 | 22 x 17 | 30 | |
| 26 x 18 | 26 x 18 | 25 x 15 | 35 x 26 | 24 x 19 | 35 | |
| 28 x 22 | 28 x 22 | 25 x 18 | 40 x 32 | 26 x 18 | 40 | |
| 30 x 23 | 30 x 23 | 30 x 20 | 50 x 40 | 26 x 20 | 45 | |
| 35 x 27 | 35 x 27 | 35 x 25 | 55 x 45 | 28 x 22 | 50 | |
| 40 x 32 | 40 x 32 | 40 x 30 | 60 x 49 | 30 x 23 | 55 | |
| 50 x 40 | 50 x 40 | 45 x 35 | 65 x 54 | 31 x 25 | 60 | |
| 60 x 50 | 60 x 50 | 50 x 40 | 70 x 58 | 33 x 28 | 65 | |
| 70 x 60 | 70 x 60 | 55 x 45 | 75 x 62 | 35 x 27 | 70 | |
| 80 x 70 | 80 x 70 | 60 x 48 | 80 x 66 | 40 x 32 | 75 | |
| 90 x 75 | 90 x 75 | | 85 x 71 | 45 x 35 | 80 | |
| 100 x 85 | 100 x 85 | | 90 x 74 | 50 x 40 | 85 | |
| 110 x 95 | 110 x 95 | | 95 x 79 | 55 x 45 | 90 | |
| 120 x 100 | 120 x 100 | | 100 x 84 | 60 x 50 | 95 | |
| 130 x 110 | 130 x 110 | | 105 x 89 | 65 x 55 | 100 | |
| 140 x 120 | 140 x 120 | | 110 x 94 | 70 x 60 | | |
| 160 x 140 | 160 x 140 | | 115 x 99 | 75 x 65 | | |
| 200 x 175 | 200 x 175 | | 120 x 104 | 80 x 70 | | |
| 250 x 230 | 250 x 230 | | 125 x 109 | 85 x 75 | | |
| 330 x 310 | 330 x 310 | | 130 x 114 | 90 x 75 | | |

max. length on inquiry, max. diameter on inquiry

TOLERANCES

according to DIN 40680

| Diameter tolerances – deflectional tolerances without grinding to DIN 40680, issue 1983 | | | | | |
|--|---------------------------------------|---------------------------------------|--|---------------------------------------|---------------------------------------|
| Nominal dimensional range for diameter or length in mm | Degree of accuracy | | Nominal dimensional range for length | Degree of accuracy | |
| | coarse Permissible deviation in mm | medium Permissible deviation in mm | | coarse Permissible deviation in mm | medium Permissible deviation in mm |
| up to 4 | ± 0,4 | ± 0,15 | up to 30 | 1,7 | 0,15 |
| above 4 up to 6 | ± 0,6 | ± 0,20 | above 30 up to 40 | 1,8 | 0,20 |
| above 6 up to 8 | ± 0,7 | ± 0,25 | above 40 up to 50 | 1,9 | 0,25 |
| above 8 up to 10 | ± 0,8 | ± 0,30 | above 50 up to 60 | 2,0 | 0,30 |
| above 10 up to 13 | ± 1,0 | ± 0,35 | above 60 up to 70 | 2,1 | 0,35 |
| above 13 up to 16 | ± 1,2 | ± 0,40 | above 70 up to 80 | 2,1 | 0,40 |
| above 16 up to 20 | ± 1,2 | ± 0,45 | above 80 up to 90 | 2,2 | 0,45 |
| above 20 up to 25 | ± 1,5 | ± 0,50 | above 90 up to 100 | 2,3 | 0,50 |
| above 25 up to 30 | ± 1,5 | ± 0,55 | above 100 up to 110 | 2,4 | 0,55 |
| above 30 up to 35 | ± 2,0 | ± 0,60 | above 110 up to 125 | 2,5 | 0,65 |
| above 35 up to 40 | ± 2,0 | ± 0,65 | above 125 up to 140 | 2,6 | 0,70 |
| above 40 up to 45 | ± 2,0 | ± 0,70 | above 140 up to 155 | 2,7 | 0,80 |
| above 45 up to 50 | ± 2,5 | ± 0,80 | above 155 up to 170 | 2,9 | 0,85 |
| above 50 up to 55 | ± 2,5 | ± 0,90 | above 170 up to 185 | 3,0 | 0,90 |
| above 55 up to 60 | ± 2,5 | ± 1,00 | above 185 up to 200 | 3,1 | 1,00 |
| above 60 up to 70 | ± 3,0 | ± 1,20 | above 200 up to 250 | 3,5 | 1,25 |
| above 70 up to 80 | ± 3,5 | ± 1,40 | above 250 up to 300 | 3,9 | 1,50 |
| above 80 up to 90 | ± 4,0 | ± 1,60 | above 300 up to 350 | 4,3 | 1,75 |
| above 90 up to 100 | ± 4,5 | ± 1,80 | above 350 up to 400 | 4,7 | 2,00 |
| above 100 up to 110 | ± 5,0 | ± 2,00 | above 400 up to 450 | 5,1 | 2,25 |
| above 110 up to 125 | ± 5,5 | ± 2,20 | above 450 up to 500 | 5,5 | 2,50 |
| above 125 up to 140 | ± 6,0 | ± 2,50 | above 500 up to 600 | 6,3 | 3,00 |
| above 140 up to 155 | ± 6,5 | ± 2,80 | above 600 up to 700 | 7,1 | 3,50 |
| above 155 up to 170 | ± 7,0 | ± 3,00 | above 700 up to 800 | 7,9 | 4,00 |
| above 170 up to 185 | ± 7,5 | ± 3,40 | above 800 up to 900 | 8,7 | 4,50 |
| above 185 up to 200 | ± 8,0 | ± 3,80 | above 900 up to 1000 | 9,5 | 5,00 |
| above 200 up to 250 | ± 9,0 | ± 4,20 | above 1000 | 1,5 + 0,8% · l | 0,5% · l |
| above 250 up to 300 | ± 10,0 | ± 4,60 | We request your inquiry for closer tolerances. | | |
| above 300 up to 350 | ± 11,0 | ± 5,00 | Manufacturing method | | Degree of accuracy coarse medium |
| above 350 up to 400 | ± 12,0 | ± 5,50 | Cast, turned, extruded for parts Ø 30 mm and above | | application customary |
| above 400 up to 450 | ± 13,0 | ± 6,10 | Extruded for parts up to Ø 30 mm, non metered pressed, metered semi wet pressed metered dry pressed, machined in the green state | | application customary |
| above 450 up to 500 | ± 14,0 | ± 6,80 | | | |
| above 500 up to 600 | ± 15,0 | ± 7,60 | | | |
| above 600 up to 700 | ± 16,0 | ± 8,30 | | | |
| above 700 up to 800 | ± 17,5 | ± 9,00 | | | |
| above 800 up to 900 | ± 19,0 | ± 9,50 | | | |
| above 900 up to 1000 | ± 20,0 | ± 10,00 | | | |
| above 1000 | ± 0,02 · d | ± 0,01 · d | | | |
| Accuracy | coarse | | medium | | |
| DIN VDE 0335, Type | 530/610 | 799 | 530/610 | 799 | |
| Manufacturing method: | | | | | |
| Cast | ● | ● | | | |
| Turned | ● | | | | |
| Extruded: Ø 30 mm and above | ● | ● | | | |
| Extruded: up to Ø 30 mm | | | ● | ● | |
| Non metered pressed | | | ● | | |
| Metered semi wet pressed | | | | | |
| Metered dry pressed | | | | ● | |
| Machined in the green state | | | ● | ● | |
| The values determined for the degree of accuracy "coarse" do not apply for first manufacture. Special agreements apply here. | | | | | |
| ● Customary manufacturing method | | | | | |

Deflection of a cylindrical body

Deflection of a noncylindrical body

EXAMPLES OF APPLICATION

for ceramic materials

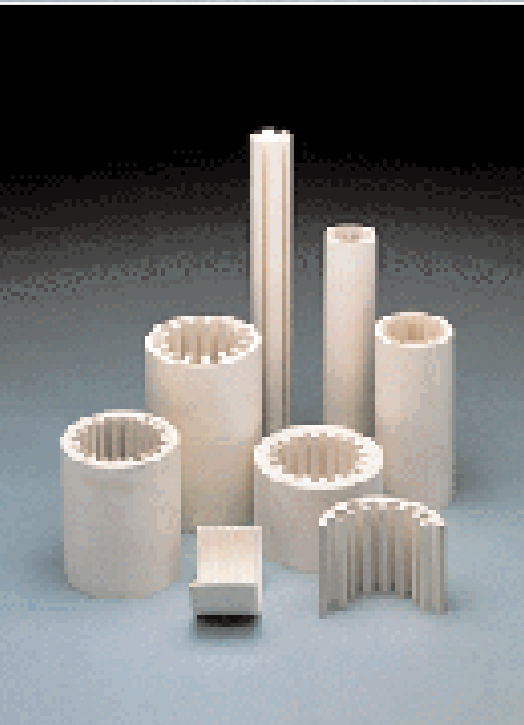

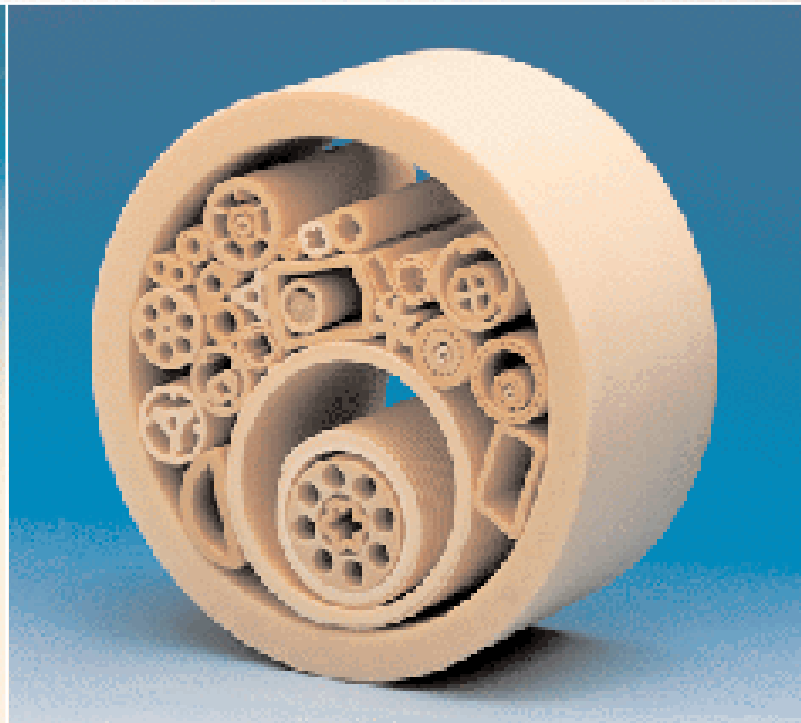

CERAMIC ROLLERS

Worldwide, HALDENWANGER is the only manufacturer of rollers for kilns and furnaces able to supply the complete programme of roller materials. With our know-how of producing different mullite and SiC-based materials we offer custom-made solutions.

Roller hearth kilns for fast firing of wall and floor tiles have been used for nearly 25 years. In this type of kiln the products to be fired are transported through the kiln by means of rotating ceramic rollers. Since the beginning HALDENWANGER has supplied the various manufacturers and users of kilns with oxide and non-oxide ceramic rollers. In the past, the diameter of rollers was up to 55 mm with a length of approx. 2000 mm. Because of increased capacity demands, the wall and floor tile industry asked for more efficient kilns. That is the reason why kilns became wider and therefore the rollers became longer. Today there are roller diameters of 30, 33.7, 40, 42, 45 and 50 mm for maximum roller length of approx. 3700 mm. This corresponds to a useable kiln width of approx. 2500 mm.

Roller tolerances have also become much tighter. Today, diameter tolerances of $\pm 0,2$ to $\pm 0,3$ mm are typical and roller bending is as small as 1,0 to 1,5 mm which corresponds to a TIR of 2-3 mm. Additionally, the overall length taper specification of no more than 1mm is today a standard requirement.

Production capacity allows us to produce nearly all standard dimensions. The rollers must have good refractory properties to guarantee a perfect operation for a given temperature and load. Furthermore, there is the need to



change rollers during kiln operation. In such cases, the high thermal gradients which rollers have to withstand means that a material must be selected having sufficient thermal shock resistance.

Oxide ceramic rollers, these are our materials Sillimantin 60, Sillimantin 65, Sillimantin 60 NG, are used in roller hearth kilns for firing wall and floor tiles. Non-oxide ceramic rollers, these are our materials Halsic-R (RSiC) and Halsic-I (SiSiC), are used in roller hearth kilns for firing sanitary ware and porcelain. These materials are used because of the better creep resistance compared to the oxide ceramic rollers.



Before installing the rollers in the kiln they must be completely dry. This is very important if the rollers are changed during operation. Drying is usually done by storing the rollers on or above the furnaces (utilisation of waste heat).

Heat losses in the kiln arise from the open ends of the roller. By using ceramic fibre plugs the rollers are sealed at both ends. The plugs usually have a maximum length of 100 mm to 200 mm.

The oxide ceramic rollers must continue to rotate whilst they are heated up or cooled down. This is very important, for example, if a roller hearth kiln is to be shut down for maintenance or technical reasons.

Stationary oxide ceramic rollers, even for a short time, results in roller bending. The drive to the rollers should never be switched off even at kiln temperatures of 500 °C to 600 °C, as frequently occurs. Stationary rollers subjected to the above-mentioned temperature will be damaged! When

the kiln is re-started, considerable breakage is to be expected. The rollers must also be kept rotating even over short breakdown periods.

HALDENWANGER ceramic rollers are used for the firing of:

- wall and floor tiles up to 1300 °C
- tableware porcelain up to 1420 °C
- sanitary porcelain up to 1300 °C
- ferrites up to 1300 °C on supporting setters
- heat treatments of metals up to 1200 °C.

Ceramic Supporting Rollers for Glass Tempering Furnaces

In glass tempering furnaces the glass is transported on rollers through the furnace. Product is run directly on the rollers, i.e. without supports.

The tempering time can be regulated via the rotational speed of the rollers

as well as by applying different heating systems.

All large sized glass plates are subject to this secondary thermal treatment because of new regulations. (single pane safety glass)

The aim of this process is to cause pre-stressing the glass through heat, so that there are no sharp splinters if the glass breaks. Like safety glass, the pane must break into many harmless particles.

Because of the sensitivity of the glass surface, the ceramic rollers used must be very smooth and free of the smallest undulation. The bending and the concentricity are very important factors, too.

Furthermore, the ceramic material must have good thermal shock resistance properties in order to withstand changes of temperature occurring in the process.

The material used for these rollers is our Fused Silica. In use today are solid as well as hollow fused silica rollers which can be supplied with mounted metal end caps.

EXAMPLES OF APPLICATIONS

for ceramic components

By means of selected examples you will recognize how we are handling and solving problems. It is shown, how we co-operate with our customers to achieve optimal results. The following pages explain the practical applications of our ceramics in furnace construction.

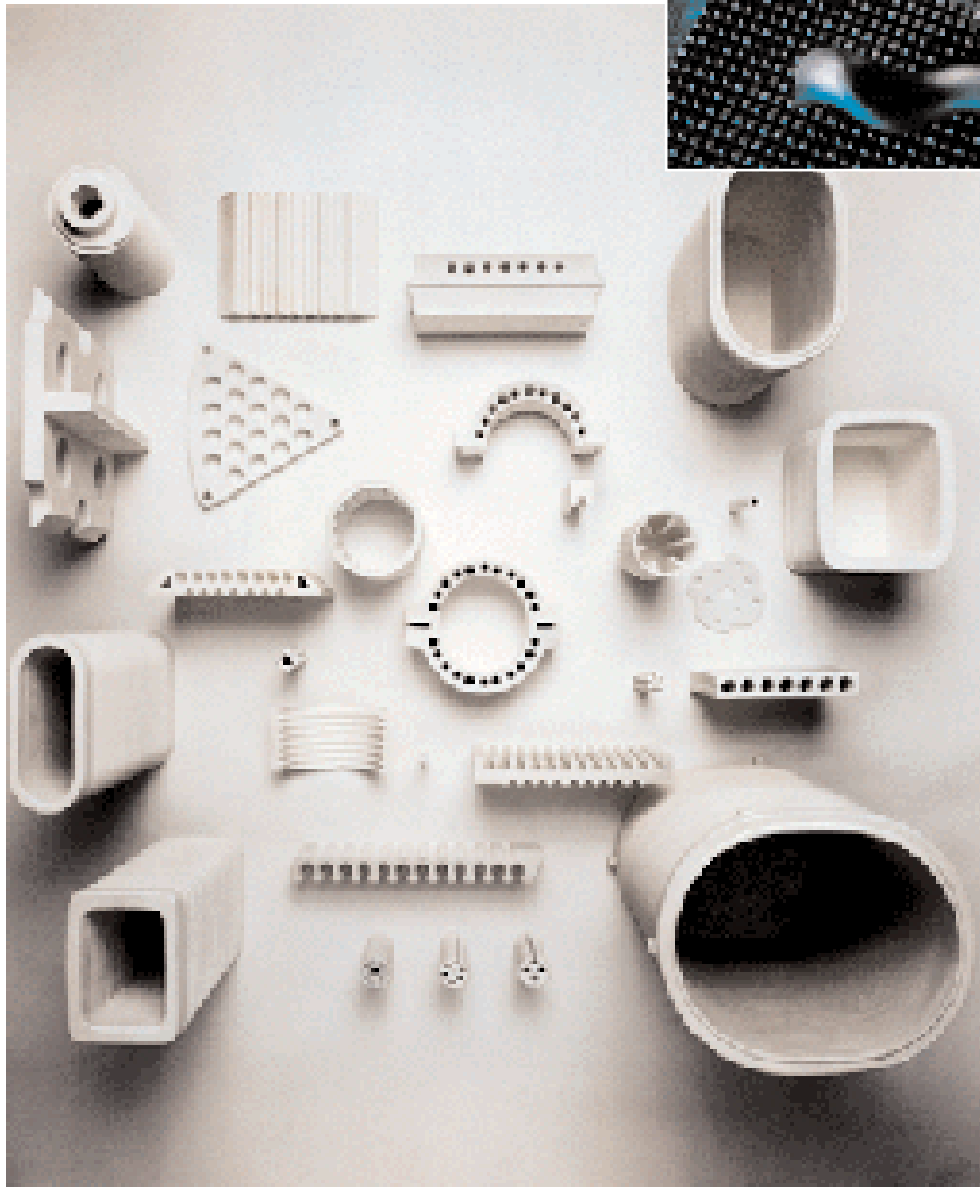
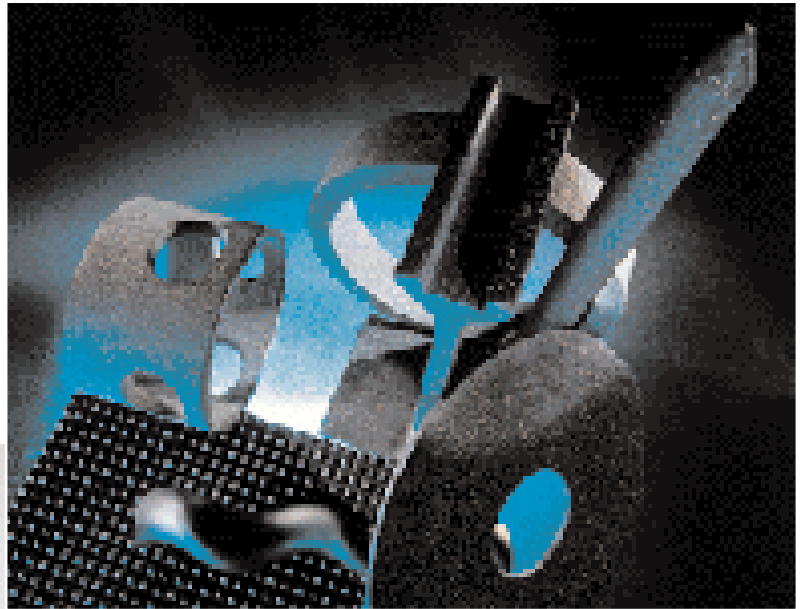

Annealing Boxes + Melting Crucibles

Annealing boxes and melting crucibles made from ceramic material are required in almost every industrial sector. The type of HALDENWANGER material used depends on the chemical or thermal stress the material has to withstand. The various sizes and geometries are determined by our customers. We are able to provide helpful advice influencing product quality and costs through our wide range of design possibilities. Such work requires a joint effort in selecting the materials and determining the product geometry.

Fused Silica

Working temperatures are possible up to 1000 °C. The low linear thermal expansion and therefore good thermal shock resistance permits short heat-up times.

Alsint Porous

Alsint porous is the right material for temperatures exceeding 1300 °C, even in a reducing atmosphere. The main characteristic of this material is its chemical resistance. Heat-up rates must be adapted to this material. It is also possible to influence the required thermal shock resistance by geometry and wall thickness.



Support Tubes

Support tubes are required for the construction of furnaces with exposed heating coils. Our material Sillimantin KS has proved itself over the years and is used by many renowned companies building kilns. All commonly used sizes of support tubes can be delivered ex stock. Special dimensions of Sillimantin 60 are manufactured (see table on page 10).

If the usual material, Sillimantin KS, does not meet the requirements of your special application, there are the following additional possibilities:

- Alsint 99,7 with its higher supporting capacity, greater supporting distance (without bending), gastightness and chemical inertness.
- Pythagoras as an impervious material has a better refractoriness than Sillimantin KS.
- Sillimantin 60 NG combines the good refractory properties of Alsint with good resistance to thermal shock.

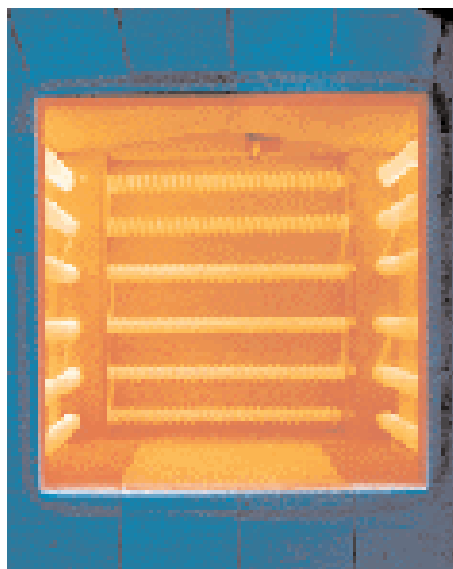

Firing Supports

In the ceramic and electrical industry firing supports or kiln furniture are required for kiln car structures. Normally in the ceramic industry tube sections, for example of the size 55 x 45 x 200 up to 300 mm, are used in order to keep the firing setters at the right distance. In the production of ferrites rectangular solid shapes of different sizes are used for the same purpose. These supports also carry the setter plates with the ferrites on them. The high mechanical strength of ceramics enables you to use small firing supports. The result is an improvement of the relation between kiln furniture and products to be fired.



Kiln Furniture Structures

Please refer to our leaflets "Halsic-R/ Halsic-RX, Halsic-I/Halsic-S" for our additional manufacturing programme.

SIZES

of muffles, open both ends

Dimensions stated here for a wide range of muffles are for Sillimantin 60 only. For Sillimantin 60 NG muffles, please use a correction factor of -5%.

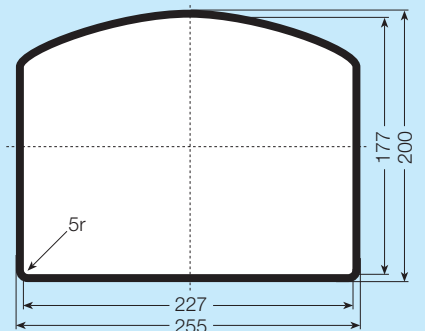
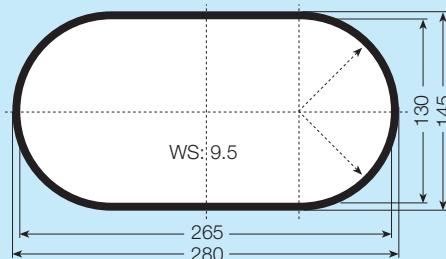
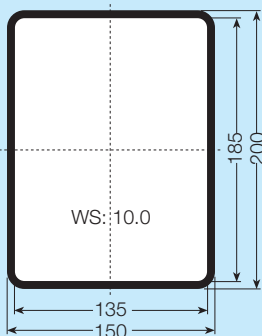
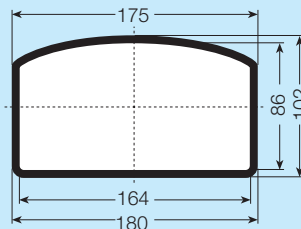
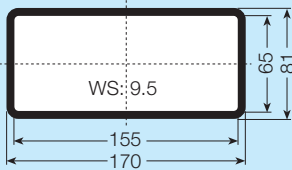
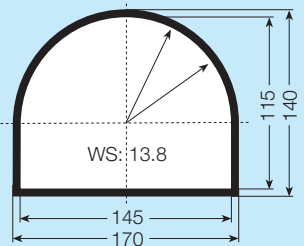
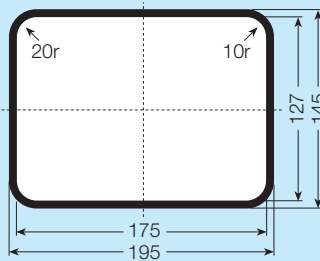
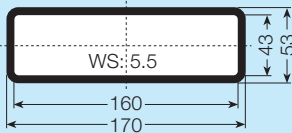
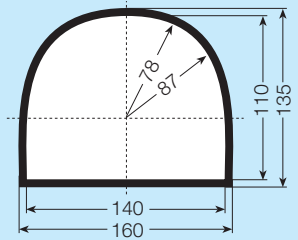
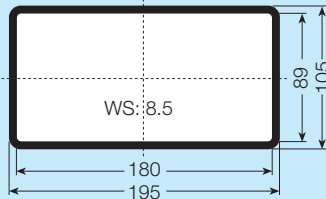
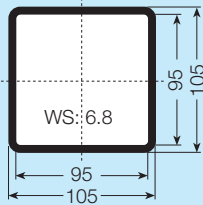
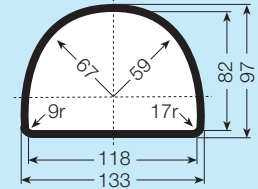
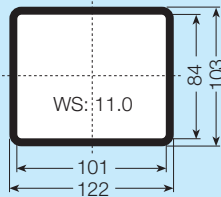
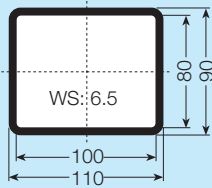
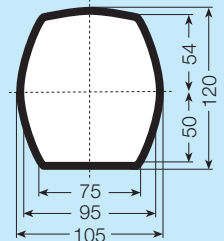
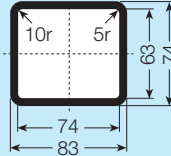
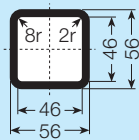

TECHNICAL CERAMICS

The objective of this brochure is to demonstrate how we are helping our customers to solve problems encountered in kiln design. However, HALDENWANGER's capabilities do not stop here. Numerous design programmes involving technical ceramics very often mean 'difficult problems' for the manufacturers and in such circumstances HALDENWANGER is the company to provide the solutions.

Technical ceramics have been used for many years in various production processes. Many new fields are being added to the already existing broad range of applications ranging from space exploration and mechanical engineering to chemistry and most sophisticated electronics.

Additional application areas for HALDENWANGER technical ceramics are:

- Mechanical applications, from shafts to cylinder liners
- Refractory applications, from saggars to heat-exchangers
- Chemical applications, from evaporating dishes to combustion boats
- Electronic and high current applications, from insulation bushes to components for electron tubes

Whatever the requirement, we believe HALDENWANGER is your competent partner right at the planning stage.

When you are next confronted with an engineering challenge for which the solution could be ceramics then remember,

HALDENWANGER is the specialist.



Special parts designed for customer applications

Alsint 99,7 insulating ring (Ø 320 mm, 4 mm wall thickness) for the satellite "COS-B"