

Move into the future with reliable measurements

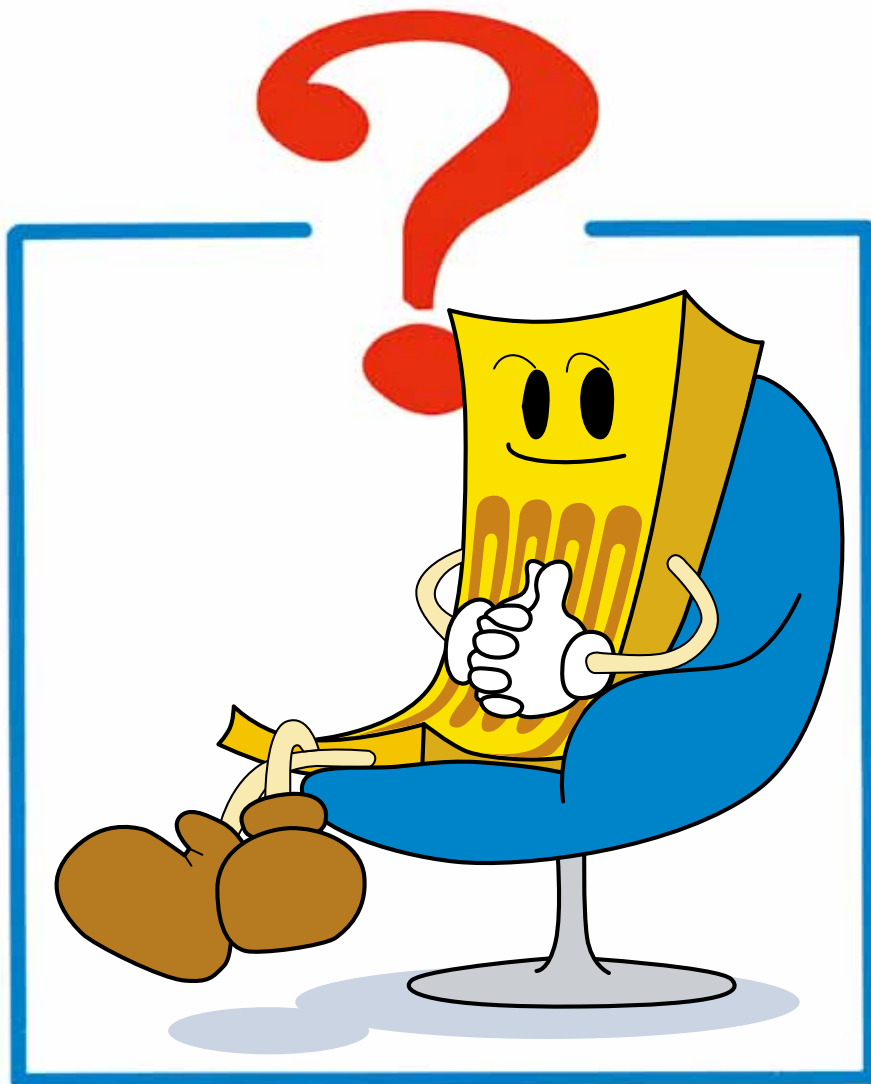

What's a STRAIN GAGE?

● Introduction to Strain Gages ●



Strain Gages

Automobiles, airplanes, bridges, buildings and many other machines and structures around us are constructed with materials and designs that endure the respective operating situations.

Today, every time a new model of an airplane, automobile or railroad vehicle is introduced, the structure is designed to be lighter to attain faster running speed and less fuel consumption. It is possible to design a lighter and more efficient product by selecting lighter materials and making them thinner for use. But the safety of the product is compromised unless the required strength is maintained. By the same token, if only the strength is taken into consideration, the weight of the product increases and the economic feasibility is impaired.

Thus, harmony between safety and economics is an extremely important factor in designing a structure. To design a structure which ensures the necessary strength while keeping such harmony, it is significant to know the **stress** borne by each material part. However, at the present scientific level, there is no technology which enables direct measurement and judgment of **stress**. So, the **strain** on the surface is measured in order to know the internal **stress**. Strain gages are the most common sensing element to measure surface strain.

Let's briefly learn about **stress and strain** and **strain gages**.

What's a strain gage?

A strain gage generates an electric signal responding to a minute dimensional change (strain) caused by applied force. The function is used in various fields including machinery, automobile, electrics, civil engineering/construction, chemical and medical treatment.

What can be revealed by a strain gage?

Use of a strain gage enables detection of minute elongation or contraction occurring on a structure. The detected elongation or contraction enables us to know "stress" generated in the structure. Stress is an important factor to verify the strength and safety of the structure. KYOWA manufactures strain gages for various purposes ranging from static strain measurement to dynamic and impact strain measurement at several hundred kHz. The wide application range makes them conveniently usable for structures of various materials and shapes.

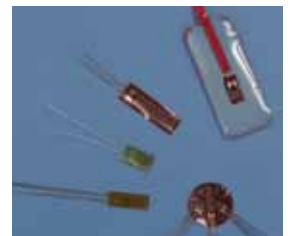

Strain gages are also used as sensor elements. Besides strain measurement, strain gages are used as sensor elements for measurement of load, pressure, acceleration, displacement and torque. Thus, they are widely used for not only experiment and research but also industrial measurement and control. Based on abundant experiences and technologies accumulated since manufacturing the first Japanese-made strain gages over 60 years before, KYOWA manufactures various types of high-performance strain gages to cope with diversified needs.

Introduction to Strain Gages



Contents

| | |
|---|-----------|
| Stress and Strain | 4 |
| Strain | 6 |
| Magnitude of Strain | 6 |
| Polarity of Strain | 6 |
| Strain Gages | 7 |
| Structure of Strain Gages | 7 |
| Principle of Strain Gages | 7 |
| Wheatstone Bridge | 9 |
| What's the Wheatstone Bridge? | 9 |
| Bridge Structure | 9 |
| Output voltage of 4-gage system | 10 |
| Output voltage of 1-gage system | 10 |
| Output voltage of 2-gage system | 10 |
| Applications of 2-gage system | 11 |
| Temperature Compensation | 12 |
| Active-dummy Method | 12 |
| Self-temperature-compensation Method | 12 |
| Principle of Self-temperature-compensation Gages | 13 |
| Principle of SELCOM Gages | 13 |
| Leadwire Temperature Compensation | 14 |
| Strain Gage Bonding Procedure | 15 |

Stress and Strain

1 **Stress** is the force an object generates inside by responding to an applied external force, P . See Fig. 1. If an object receives an external force from the top, it internally generates a repelling force to maintain the original shape. The repelling force is called internal force and the internal force divided by the cross-sectional area of the object (a column in this example) is called **stress**, which is expressed as a unit of Pa (Pascal) or N/m^2 . Suppose that the cross-sectional area of the column is A (m^2) and the external force is P (N, Newton). Since external force = internal force, stress, σ (sigma), is:

$$\sigma = \frac{P}{A} \text{ (Pa or N/m}^2\text{)}$$

Since the direction of the external force is vertical to the cross-sectional area, A , the stress is called vertical stress.

Fig. 1

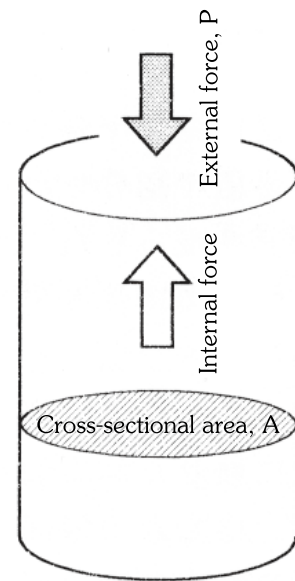

2 When a bar is pulled, it elongates by ΔL , and thus it lengthens to L (original length) + ΔL (change in length). The ratio of this elongation (or contraction), ΔL , to the original length, L , is called **strain**, which is expressed in ϵ (epsilon):

$$\epsilon_1 = \frac{\Delta L \text{ (change in length)}}{L \text{ (original length)}}$$

Strain in the same tensile (or compressive) direction as the external force is called **longitudinal strain**. Since strain is an elongation (or contraction) ratio, it is an absolute number having no unit. Usually, the ratio is an extremely small value, and thus a strain value is expressed by suffixing “ $\times 10^{-6}$ (parts per million) strain,” “ $\mu\text{m}/\text{m}$ ” or “ $\mu\epsilon$.”

Fig. 2

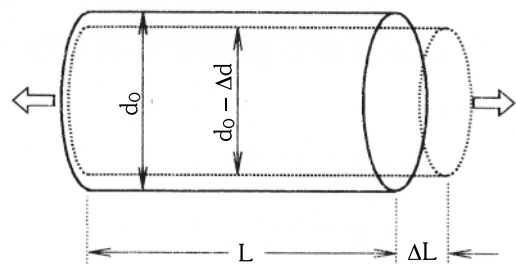

Hooke's law (law of elasticity)

In most materials, a proportional relation is found between stress and strain borne, as long as the elastic limit is not exceeded. This relation was experimentally revealed by Hooke in 1678, and thus it is called “Hooke's law” or the “law of elasticity.” The stress limit to which a material maintains this proportional relation between stress and strain is called the “proportional limit” (each material has a different proportional limit and elastic limit). Most of today's theoretical calculations of material strength are based on this law and are applied to designing machinery and structures.

Robert Hooke (1635-1703)

English scientist. Graduate of Cambridge University. Having an excellent talent especially for mathematics, he served as a professor of geometry at Gresham College. He experimentally verified that the center of gravity of the earth traces an ellipse around the sun, discovered a star of the first magnitude in Orion, and revealed the renowned “Hooke's law” in 1678.

The pulled bar becomes thinner while lengthening. Suppose that the original diameter, d_0 , is made thinner by Δd . Then, the strain in the diametrical direction is:

$$\epsilon_2 = \frac{-\Delta d}{d_0}$$

Strain in the orthogonal direction to the external force is called **lateral strain**. Each material has a certain ratio of **lateral strain** to **longitudinal strain**, with most materials showing a value around 0.3. This ratio is called Poisson's ratio, which is expressed in ν (nu):

$$\nu = \left| \frac{\epsilon_2}{\epsilon_1} \right| = 0.3$$

3 With various materials, the relation between strain and stress has already been obtained experimentally. Fig. 3 graphs a typical relation between stress and strain on common steel (mild steel). The region where stress and strain have a linear relation is called the proportional limit, which satisfies the Hooke's law.

$$\sigma = E \cdot \epsilon \quad \text{or} \quad \frac{\sigma}{\epsilon} = E$$

The proportional constant, E , between stress and strain in the equation above is called the modulus of longitudinal elasticity or Young's modulus, the value of which depends on the materials.

As described above, stress can be known through measurement of the strain initiated by external force, even though it cannot be measured directly.

Fig. 3

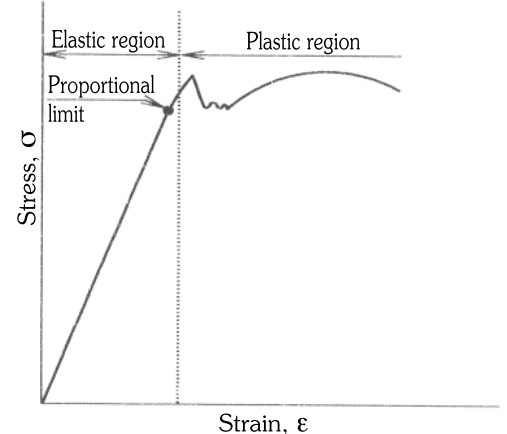

Siméon Denis Poisson (1781-1840)

French mathematician/mathematical physicist. Born in Pithiviers, Loiret, France and brought up in Fontainebleau. He entered l'Ecole Polytechnique in 1798 and became a professor following Fourier in 1806. His work titled "Traité du mécanique (Treatise on Mechanics)" long played the role of a standard textbook.

Especially renowned is Poisson's equation in potential theory in mass. In the mathematic field, he achieved a series of studies on the definite integral and the Fourier series. Besides the abovementioned mechanics field, he is also known in the field of mathematical physics, where he developed the electromagnetic theory, and in astronomy, where he published many papers. Late in life, he was raised to the peerage in France. He died in Paris.

Strain

Magnitude of Strain

How minute is the magnitude of strain? To understand this, let's calculate the strain initiated in an iron bar of 1 square cm ($1 \times 10^{-4} \text{ m}^2$) which vertically receives an external force of 10 kN from the top.

First, the stress produced by the strain is:

$$\sigma = \frac{P}{A} = \frac{10 \text{ kN}}{1 \times 10^{-4} \text{ m}^2} = \frac{10 \times 10^3 \text{ N}}{1 \times 10^{-4} \text{ m}^2} = 100 \text{ MPa}$$

Substitute this value for σ in the stress-strain relational expression (page 5) to calculate the strain:

$$\epsilon = \frac{\sigma}{E} = \frac{100 \text{ MPa}}{206 \text{ GPa}} = \frac{100 \times 10^6}{206 \times 10^9} = 4.85 \times 10^{-4}$$

Since strain is usually expressed in parts per million,

$$\epsilon = \frac{485}{1000000} = 485 \times 10^{-6}$$

The strain quantity is expressed as 485 $\mu\text{m}/\text{m}$, 485 $\mu\epsilon$ or 485×10^{-6} strain.

Polarity of Strain

There exist tensile strain (elongation) and compressive strain (contraction). To distinguish between them, a sign is prefixed as follows:

Plus (+) to tensile strain (elongation)

Minus (-) to compressive strain (contraction)

Fig. 4

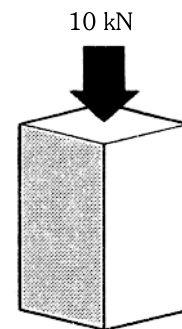

Iron bar ($E = 206 \text{ GPa}$)
of $1 \times 10^{-4} \text{ m}^2$ (1 sq.cm)

Prefixes meaning powers of 10

| Symbol | Name | Multiple |
|--------|--------|-----------|
| G | Giga- | 10^9 |
| M | Mega- | 10^6 |
| k | Kilo- | 10^3 |
| h | Hecto- | 10^2 |
| da | Deka- | 10^1 |
| d | Deci- | 10^{-1} |
| c | Centi- | 10^{-2} |
| m | Milli- | 10^{-3} |
| μ | Micro- | 10^{-6} |

Young's modulus

Also called modulus of elasticity in tension or modulus of longitudinal elasticity. With materials obeying Hooke's law, Young's modulus stands for a ratio of simple vertical stress to vertical strain occurring in the stress direction within the proportional limit. Since this modulus was determined first among various coefficients of elasticity, it is generally expressed in E, the first letter of elasticity. Since the 18th century, it has been known that vertical stress is proportional to vertical strain, as long as the proportional limit is not exceeded. But the proportional constant, i.e. the value of the modulus of longitudinal elasticity, had been unknown. Young was first to determine the constant, and thus it was named Young's modulus in his honor.

Thomas Young (1773-1829)

English physician, physicist and archaeologist. His genius early asserted itself and he has been known as a pioneer in reviving the light wave theory. From advocating the theory for several years, he succeeded in discovering interference of light and in explaining Newton's ring and diffraction phenomenon in the wave theory. He is especially renowned for presenting Young's modulus and giving energy the same scientific connotation as used at the present.

Strain Gages

1 Structure of Strain Gages

There are many types of strain gages. Among them, a universal strain gage has a structure such that a **grid-shaped sensing element** of thin metallic resistive foil (3 to 6 μm thick) is put on a **base** of thin plastic film (15 to 16 μm thick) and is laminated with a thin film.

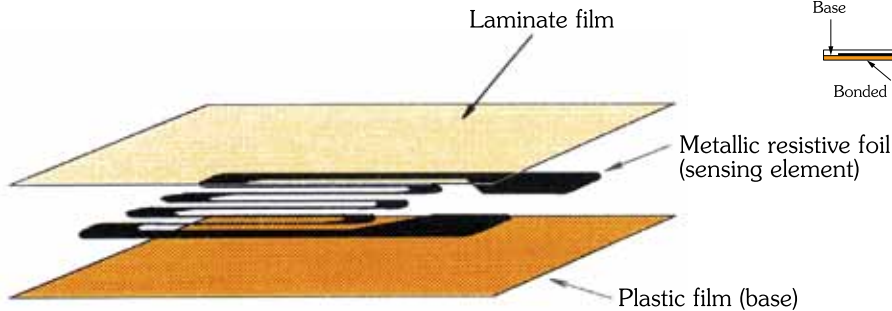

KFG gage

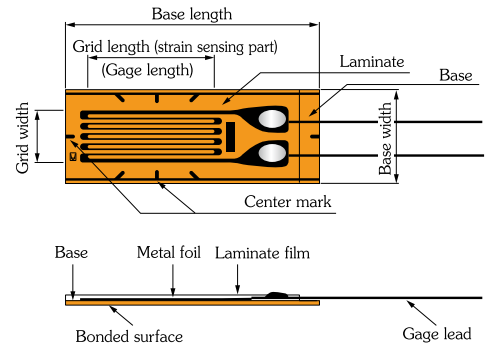

2 Principle of Strain Gages

The strain gage is tightly bonded to a measuring object so that the sensing element (metallic resistive foil) may elongate or contract according to the strain borne by the measuring object. When bearing mechanical elongation or contraction, most metals undergo a change in electric resistance. The strain gage applies this principle to strain measurement through the resistance change. Generally, the sensing element of the strain gage is made of a copper-nickel alloy foil. The alloy foil has a **rate of resistance change** proportional to **strain** with a certain constant.

Typical gage patterns

For concentrated stress measurement
Uniaxial 5-element,
90°

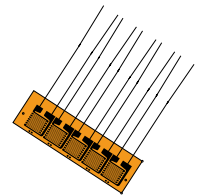

For measurement of Poisson's ratio, etc.
Biaxial stacked rosette,
round base

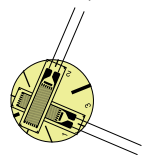

For stress analysis, etc.
Triaxial stacked rosette,
round base

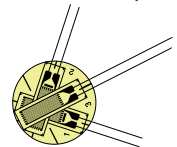

Types of strain measuring methods

There are various types of strain measuring methods, which may roughly be classified into mechanical, optical, and electrical methods. Since strain on a substance may geometrically be regarded as a distance change between two points on the substance, all methods are but a way of measuring such a distance change. If the elastic modulus of the object material is known, strain measurement enables calculation of stress. Thus, strain measurement is often performed to determine the stress initiated in the substance by an external force, rather than to know the strain quantity.

Let's express the principle as follows:

$$\frac{\Delta R}{R} = K_s \cdot \epsilon$$

where, R: Original resistance of strain gage, Ω (ohm)

ΔR : Elongation or contraction initiated resistance change, Ω (ohm)

K_s : Proportional constant (called gage factor)

ϵ : Strain

The gage factor, K_s , differs depending on the metallic materials. The copper-nickel alloy provides a gage factor around 2. Thus, a strain gage using this alloy for the sensing element enables conversion of mechanical strain to a corresponding electrical resistance change. However, since strain is an invisible infinitesimal phenomenon, the resistance change caused by strain is extremely small.

For example, let's calculate the resistance change on a strain gage caused by 1000×10^{-6} strain.

Generally, the resistance of a strain gage is 120Ω , and thus the following equation is established:

$$\frac{\Delta R}{120 (\Omega)} = 2 \times 1000 \times 10^{-6}$$

$$\Delta R = 120 \times 2 \times 1000 \times 10^{-6} = 0.24 \Omega$$

The rate of resistance change is:

$$\frac{\Delta R}{R} = \frac{0.24}{120} = 0.002 = 0.2\%$$

In fact, it is extremely difficult to accurately measure such a minute resistance change, which cannot be measured with a conventional ohmmeter. Accordingly, minute resistance changes are measured with a dedicated strain amplifier using an electric circuit called a Wheatstone bridge.

| Application | Gage resistance |
|-----------------------------|----------------------|
| Bending strain compensation | 60 Ω |
| General stress measurement | 120 Ω |
| Transducer | 350 to 1000 Ω |

Strain measurement with strain gages

Since the handling method is comparatively easy, a strain gage has widely been used, enabling strain measurement to imply measurement with a strain gage in most cases. When a fine metallic wire is pulled, it has its electric resistance changed. It is experimentally demonstrated that most metals have their electric resistance changed in proportion to elongation or contraction in the elastic region. By bonding such a fine metallic wire to the surface of an object, strain on the object can be determined by measuring the resistance change. The resistance wire should be 1/50 to 1/200 mm in diameter and provide high specific resistance. Generally, a copper-nickel alloy wire is used.

Usually, an instrument equipped with a bridge circuit and amplifier is used to measure the resistance change. Since a strain gage can follow elongation/contraction occurring at several hundred kHz, its combination with a proper measuring instrument enables measurement of impactive phenomena. Measurement of fluctuating stress on parts of running vehicles or flying aircraft was made possible using a strain gage and a proper mating instrument.

Wheatstone Bridge

1 What's the Wheatstone Bridge?

The Wheatstone bridge is an electric circuit suitable for detection of minute resistance changes. It is therefore used to measure resistance changes of a strain gage. The bridge is configured by combining four resistors as shown in Fig. 5.

Suppose:

$$R1 = R2 = R3 = R4, \text{ or}$$

$$R1 \times R3 = R2 \times R4$$

Then, whatever voltage is applied to the input, the output, e , is zero. Such a bridge status is called "balanced." When the bridge loses the balance, it outputs a voltage corresponding to the resistance change.

As shown in Fig. 6, a strain gage is connected in place of $R1$ in the circuit. When the gage bears strain and initiates a resistance change, ΔR , the bridge outputs a corresponding voltage, e .

$$e = \frac{1}{4} \cdot \frac{\Delta R}{R} \cdot E$$

That is,

$$e = \frac{1}{4} \cdot K_s \cdot \varepsilon \cdot E$$

Since values other than ε are known values, strain, ε , can be determined by measuring the bridge output voltage.

2 Bridge Structures

The structure described above is called a 1-gage system since only one gage is connected to the bridge. Besides the 1-gage system, there are 2-gage and 4-gage systems.

2-gage system

With the 2-gage system, gages are connected to the bridge in either of two ways, shown in Fig. 7.

Fig. 5

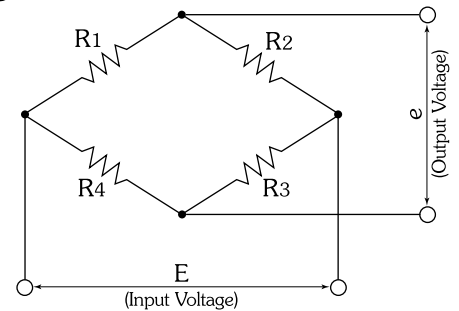

Fig. 6

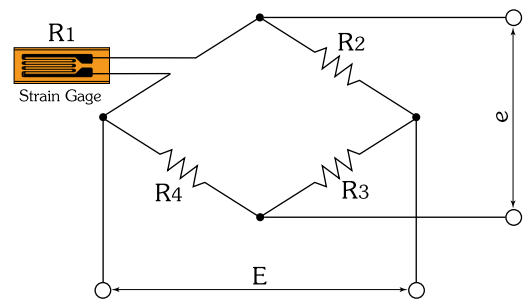
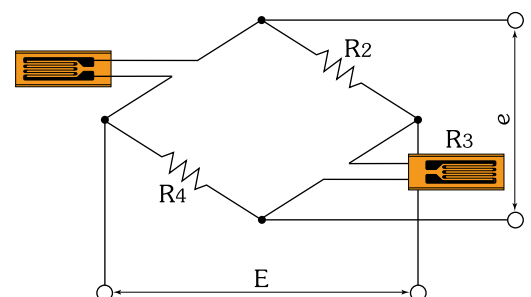
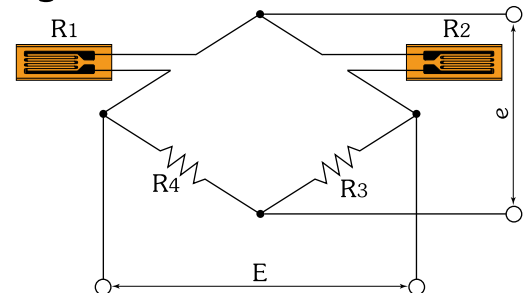

Fig. 7



Output voltage of 4-gage system

The 4-gage system has four gages connected one each to all four sides of the bridge. While this system is rarely used for strain measurement, it is frequently applied to strain-gage transducers.

When the gages at the four sides have their resistance changed to $R_1 + \Delta R_1$, $R_2 + \Delta R_2$, $R_3 + \Delta R_3$ and $R_4 + \Delta R_4$, respectively, the bridge output voltage, e , is:

$$e = \frac{1}{4} \left(\frac{\Delta R_1}{R_1} - \frac{\Delta R_2}{R_2} + \frac{\Delta R_3}{R_3} - \frac{\Delta R_4}{R_4} \right) E$$

If the gages at the four sides are equal in specifications including the gage factor, K_s , and receive strains, ϵ_1 , ϵ_2 , ϵ_3 and ϵ_4 , respectively, the equation above will be:

$$e = \frac{1}{4} \cdot K_s (\epsilon_1 - \epsilon_2 + \epsilon_3 - \epsilon_4) E$$

Output voltage of 1-gage system

In the cited equation for the 4-gage system, the 1-gage system undergoes resistance change, R_1 , at one side only. Thus, the output voltage is:

$$e = \frac{1}{4} \cdot \frac{\Delta R_1}{R_1} \cdot E$$

or, $e = \frac{1}{4} \cdot K_s \cdot \epsilon_1 \cdot E$

In almost all cases, general strain measurement is performed using the 1-gage system.

Output voltage of 2-gage system

Two sides among the four initiate resistance change. Thus, the 2-gage system in the case of Fig. 10 (a), provides the following output voltage:

$$e = \frac{1}{4} \left(\frac{\Delta R_1}{R_1} - \frac{\Delta R_2}{R_2} \right) E$$

or, $e = \frac{1}{4} K_s (\epsilon_1 - \epsilon_2) E$

In the case of Fig. 10 (b),

$$e = \frac{1}{4} \left(\frac{\Delta R_1}{R_1} + \frac{\Delta R_3}{R_3} \right) E$$

or, $e = \frac{1}{4} K_s (\epsilon_1 + \epsilon_3) E$

Fig. 8

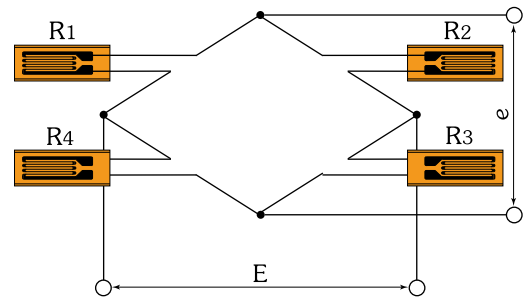

Fig. 9

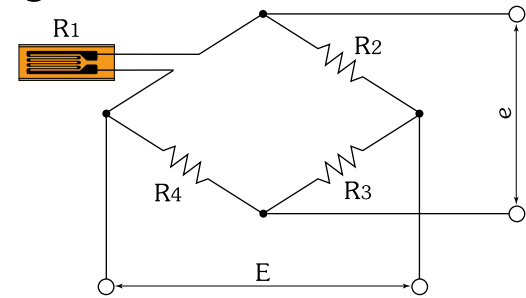
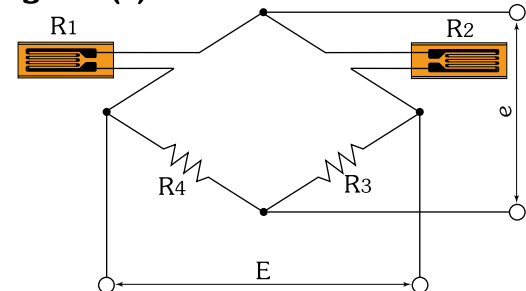
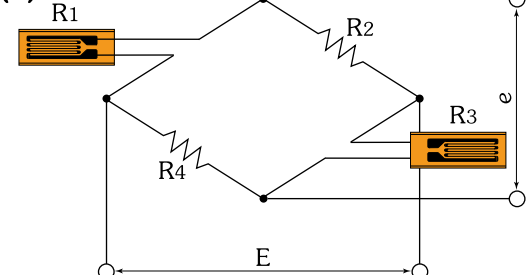

Fig. 10 (a)



(b)



That is to say, the strain borne by the second gage is subtracted from, or added to, the strain borne by the first gage, depending on the sides to which the two gages are inserted, adjacent or opposite.

Applications of 2-gage system

The 2-gage system is mostly used for the following case. To separately know either the bending or tensile strain an external force applies to a cantilever, one gage is bonded to the same position at both the top and bottom, as shown in Fig. 11.

These two gages are connected to adjacent or opposite sides of the bridge, and the bending or tensile strain can be measured separately. That is, gage ① senses the tensile (plus) strain and gage ② senses the compressive (minus) strain. The absolute strain value is the same irrespective of polarities, provided that the two gages are at the same distance from the end of the cantilever.

To measure the bending strain only by offsetting the tensile strain, gage ② is connected to the adjacent side of the bridge. Then, the output, e , of the bridge is:

$$e = \frac{1}{4} K_s (\epsilon_1 - \epsilon_2) E$$

Since tensile strains on gages ① and ② are plus and the same in magnitude, $(\epsilon_1 - \epsilon_2)$ in the equation is 0, thereby making the output, e , zero. On the other hand, the bending strain on gage ① is plus and that on gage ② is minus. Thus, ϵ_2 is added to ϵ_1 , thereby doubling the output. That is, the bridge configuration shown in Fig. 12 enables measurement of the bending strain only.

If gage ② is connected to the opposite side, the output, e , of the bridge is:

$$e = \frac{1}{4} K_s (\epsilon_1 + \epsilon_3) E$$

Thus, contrary to the above, the bridge output is zero for the bending strain while doubled for the tensile strain. That is, the bridge configuration shown in Fig. 13 cancels the bending strain and enables measurement of the tensile strain only.

Fig. 11

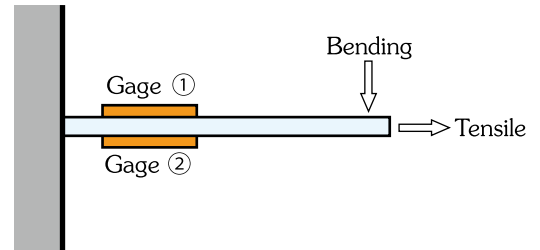

Fig. 12

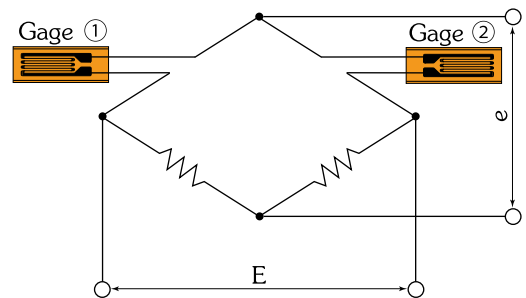
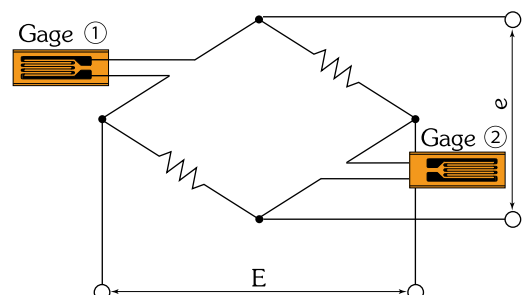

Fig. 13



Temperature Compensation

One of the problems of strain measurement is thermal effect. Besides external force, changing temperatures elongate or contract the measuring object with a certain linear expansion coefficient. Accordingly, a strain gage bonded to the object bears thermally-induced apparent strain. Temperature compensation solves this problem.

1 Active-dummy Method

The active-dummy method uses the 2-gage system where an active gage, A, is bonded to the measuring object and a dummy gage, D, is bonded to a dummy block which is free from the stress of the measuring object but under the same temperature condition as that affecting the measuring object. The dummy block should be made of the same material as the measuring object.

As shown in Fig. 14, the two gages are connected to adjacent sides of the bridge. Since the measuring object and the dummy block are under the same temperature condition, thermally-induced elongation or contraction is the same on both of them. Thus, gages A and B bear the same thermally-induced strain, which is compensated to let the output, e , be zero because these gages are connected to adjacent sides.

2 Self-temperature-compensation Method

Theoretically, the active-dummy method described above is an ideal temperature compensation method. But the method involves problems in the form of an extra task to bond two gages and install the dummy block. To solve these problems, the self-temperature-compensation gage (SELCOM gage) was developed as the method of compensating temperature with a single gage.

With the self-temperature-compensation gage, the temperature coefficient of resistance of the sensing element is controlled based on the linear expansion coefficient of the measuring object. Thus, the gage enables strain measurement without receiving any thermal effect if it is matched with the measuring object. Except for some special models, all recent KYOWA strain gages apply the self-temperature-compensation method.

Fig. 14

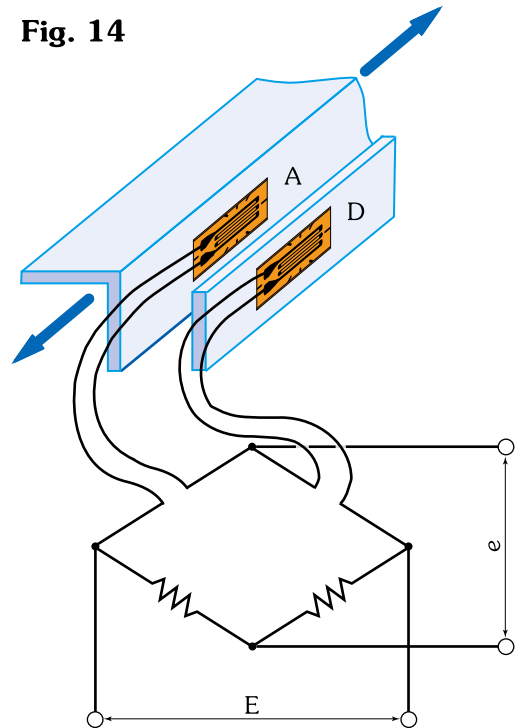

Principle of Self-temperature-compensation Gages

As described in the previous section, except for some special models, all recent KYOWA strain gages are self-temperature-compensation gages (SELCOM gages). This section briefly describes the principle by which they work.

1 Principle of SELCOM Gages

Suppose that the linear expansion coefficient of the measuring object is β_s and that of the resistive element of the strain gage is β_g . When the strain gage is bonded to the measuring object as shown in Fig. 15, the strain gage bears thermally-induced apparent strain/ $^{\circ}\text{C}$, ϵ_T , as follows:

$$\epsilon_T = \frac{\alpha}{K_s} + (\beta_s - \beta_g)$$

where, α : Temperature coefficient of resistance of resistive element

K_s : Gage factor of strain gage

The gage factor, K_s , is determined by the material of the resistive element, and the linear expansion coefficients, β_s and β_g , are determined by the materials of the measuring object and the resistive element, respectively. Thus, controlling the temperature coefficient of resistance, α , of the resistive element suffices to make the thermally-induced apparent strain, ϵ_T , zero in the above equation.

$$\begin{aligned} \alpha &= -K_s (\beta_s - \beta_g) \\ &= K_s (\beta_g - \beta_s) \end{aligned}$$

The temperature coefficient of resistance, α , of the resistive element can be controlled through heat treatment in the foil production process. Since it is adjusted to the linear expansion coefficient of the intended measuring object, application of the gage to other than the intended materials not only voids temperature compensation but also causes large measurement errors.

Fig. 15

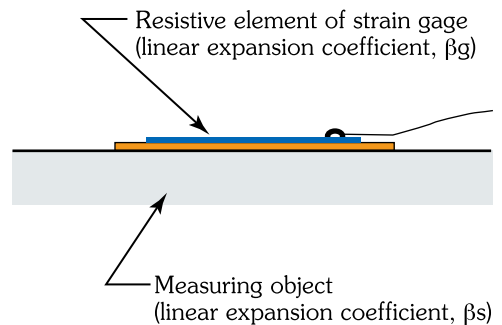

SELCOM gage applicable materials

| Applicable materials | Linear expansion coefficient |
|---|--------------------------------------|
| Composite materials, diamond, etc. | $1 \times 10^{-6}/^{\circ}\text{C}$ |
| Composite materials, silicon, sulfur, etc. | $3 \times 10^{-6}/^{\circ}\text{C}$ |
| Composite materials, lumber, tungsten, etc. | $5 \times 10^{-6}/^{\circ}\text{C}$ |
| Composite materials, tantalum, etc. | $6 \times 10^{-6}/^{\circ}\text{C}$ |
| Composite materials, titanium, platinum, etc. | $9 \times 10^{-6}/^{\circ}\text{C}$ |
| Common steel, SUS 631, etc. | $11 \times 10^{-6}/^{\circ}\text{C}$ |

| Applicable materials | Linear expansion coefficient |
|---|--------------------------------------|
| Corrosion/heat-resistant alloys, nickel, etc. | $13 \times 10^{-6}/^{\circ}\text{C}$ |
| Stainless steel, SUS 304, copper, etc. | $16 \times 10^{-6}/^{\circ}\text{C}$ |
| 2024-T4 aluminum, brass, tin, etc. | $23 \times 10^{-6}/^{\circ}\text{C}$ |
| Magnesium alloy, composite materials, etc. | $27 \times 10^{-6}/^{\circ}\text{C}$ |
| Acrylic resin, polycarbonate | $65 \times 10^{-6}/^{\circ}\text{C}$ |

Leadwire Temperature Compensation

The use of the self-temperature-compensation gage (SELCOM gage) eliminates the thermal effect from the gage output. But leadwires between the gage and the strain-gage bridge are also affected by ambient temperature. This problem too should be solved.

With the 1-gage 2-wire system shown in Fig. 16, the resistance of each leadwire is inserted in series to the gage, and thus leadwires do not generate any thermal problem if they are short. But if they are long, leadwires adversely affect measurement. The copper used for leadwires has a temperature coefficient of resistance of $3.93 \times 10^{-3}/^{\circ}\text{C}$. For example, if leadwires 0.3 mm^2 and $0.062 \text{ } \Omega/\text{m}$ each are laid to 10 m length (reciprocating distance: 20 m), a temperature increase by 1°C produces an output of 20×10^{-6} strain when referred to a strain quantity.

Fig. 16

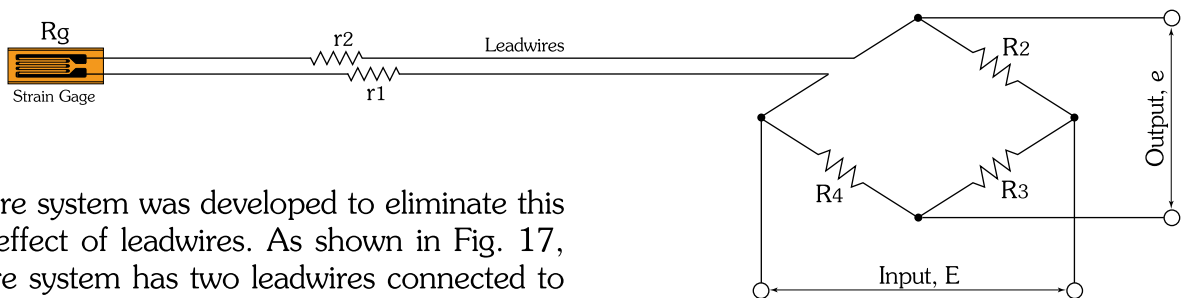

The 3-wire system was developed to eliminate this thermal effect of leadwires. As shown in Fig. 17, the 3-wire system has two leadwires connected to one of the gage leads and one leadwire connected to the other.

Fig. 17

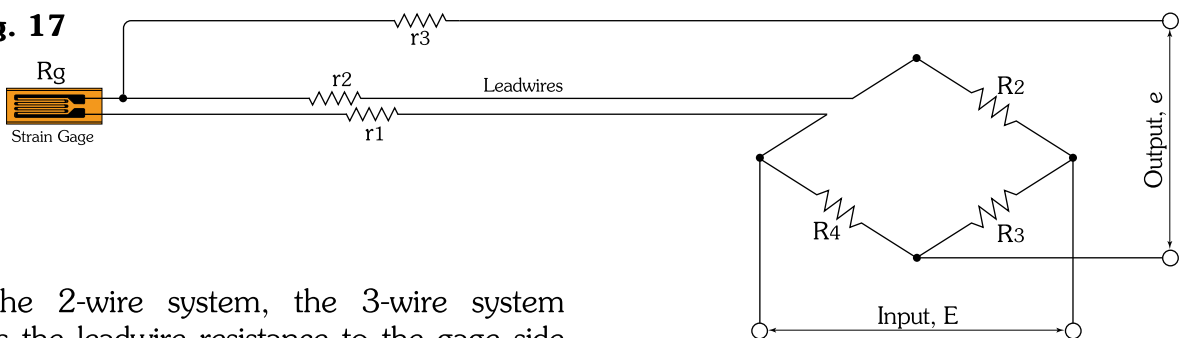

Unlike the 2-wire system, the 3-wire system distributes the leadwire resistance to the gage side of the bridge and to the adjacent side. In Fig. 17, the leadwire resistance r_1 enters in series to R_g and the leadwire resistance r_2 enters in series to R_2 . That is, the leadwire resistance is distributed to adjacent sides of the bridge. The leadwire resistance r_3 is connected to the outside (output side) of the bridge, and thus it produces virtually no effect on measurement.

Strain Gage Bonding Procedure

The strain-gage bonding method differs depending on the type of the strain gage, the applied adhesive and operating environment. Here, for the purpose of strain measurement at normal temperatures in a room, we show how to bond a typical leadwire-equipped KFG gage to a mild steel specimen using CC-33A quick-curing cyanoacrylate adhesive.

(1) Select strain gage.

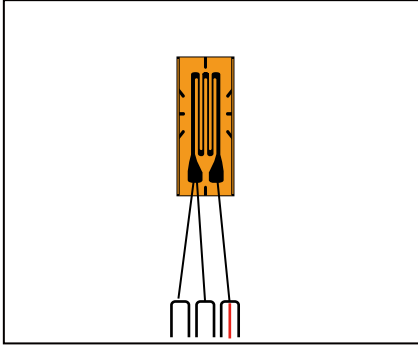

Select the strain gage model and gage length which meet the requirements of the measuring object and purpose. For the linear expansion coefficient of the gage applicable to the measuring object, refer to page 13. Select the most suitable one from the 11 choices.

(5) Apply adhesive.

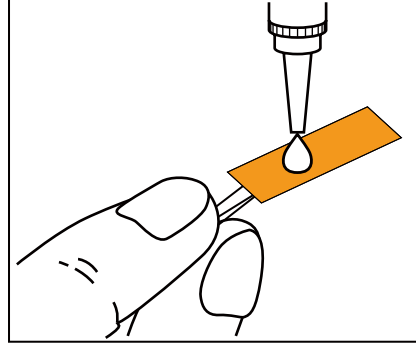

Ascertain the back and front of the strain gage. Apply a drop of CC-33A adhesive to the back of the strain gage. Do not spread the adhesive. If spreading occurs, curing is adversely accelerated, thereby lowering the adhesive strength.

(2) Remove dust and paint.

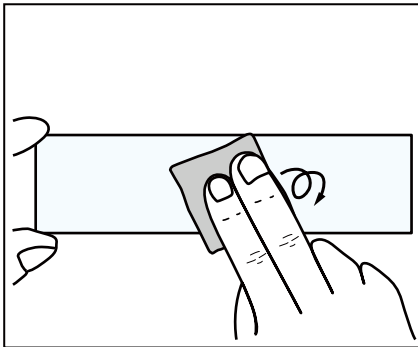

Using a sand cloth (#200 to 300), polish the strain-gage bonding site over a wider area than the strain-gage size. Wipe off paint, rust and plating, if any, with a grinder or sand blast before polishing.

(6) Bond strain gage to measuring site.

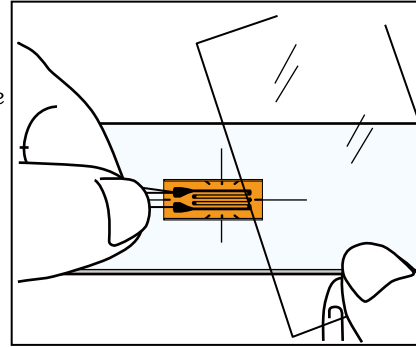

After applying a drop of the adhesive, put the strain gage on the measuring site while lining up the center marks with the marking-off lines.

(3) Remove grease from bonding surface and clean.

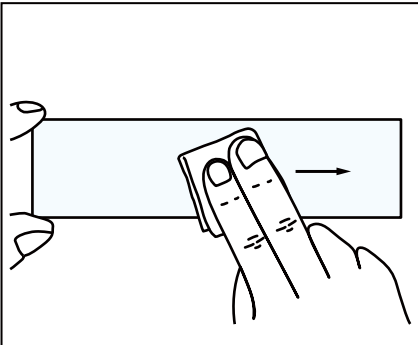

Using an industrial tissue paper (SILBON paper) dipped in acetone, clean the strain-gage bonding site. Strongly wipe the surface in a single direction to collect dust and then remove by wiping in the same direction. Reciprocal wiping causes dust to move back and forth and does not ensure cleaning.

(7) Press strain gage.

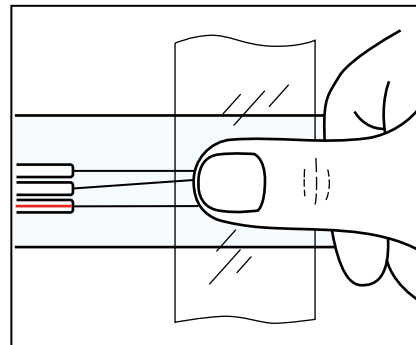

Cover the strain gage with the accessory polyethylene sheet and press it over the sheet with a thumb. Quickly perform steps (5) to (7) as a series of actions. Once the strain gage is placed on the bonding site, do not lift it to adjust the position. The adhesive strength will be extremely lowered.

(4) Decide bonding position.

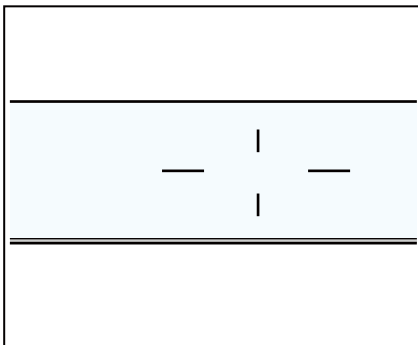

Using a #2 pencil or a marking-off pin, mark the measuring site in the strain direction. When using a marking-off pin, take care not to deeply scratch the strain-gage bonding surface.

(8) Complete bonding work.

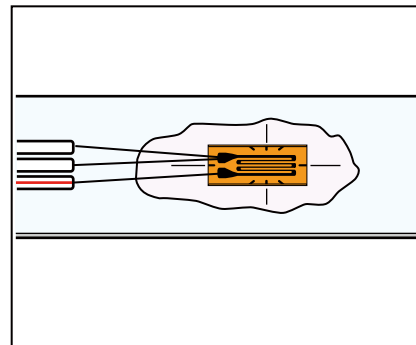

After pressing the strain gage with a thumb for one minute or so, remove the polyethylene sheet and make sure the strain gage is securely bonded. The above steps complete the bonding work. However, good measurement results are available after 60 minutes of complete curing of the adhesive.

For more useful information, contact
your local KYOWA sales/service distributor
or KYOWA (overseas@kyowa-ei.co.jp).
Thank you.

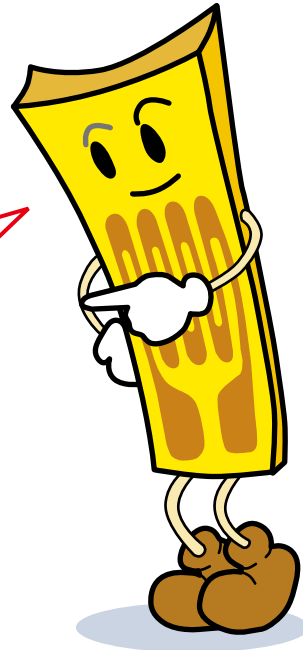

www.kyowa-ei.com



JQA-QMA0821

Move into the future with reliable measurements

 **KYOWA**

KYOWA ELECTRONIC INSTRUMENTS CO., LTD.

Overseas Department:

3-5-1, Chofugaoka, Chofu, Tokyo 182-8520, Japan

Phone: +81-42-489-7220 Facsimile: +81-42-489-1122

<http://www.kyowa-ei.com>

e-mail: overseas@kyowa-ei.co.jp

Cat. No. 914B-U53

Specifications are subject to change without notice for improvement.



Safety precautions

Be sure to observe the safety precautions given in the instruction manual, in order to ensure correct and safe operation.

Manufacturer's Distributor