

5.3 EXTERNAL FEEDBACK CONNECTOR DETAILS

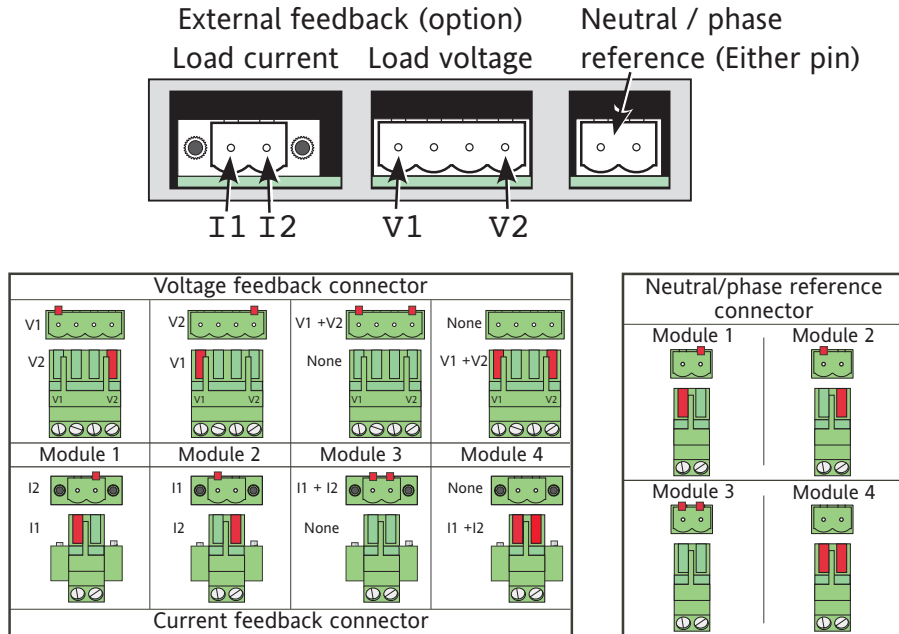

Figure 5.3 External feedback connector pinout and polarising details

Service instructions EPower™ driver and power modules

1 INTRODUCTION

These instructions are intended to assist in the fitting of spare parts either as replacements or as new features. The document gives disassembly instructions for the various driver and power modules that make up an EPower system. The user should follow only those parts of the instructions which are relevant to requirements.

WARNING

When the module covers are removed, large areas (particularly inside the power modules) of conductor are revealed which can be at lethal voltages of up to 690V ac. There is no indication inside the modules that such voltages are present. It is therefore essential that the user personally ensures that all signal and supply voltages have been isolated before the covers are removed, and that the supply is secured against accidental switch on.

WARNING

EPower units can reach elevated temperatures during operation - the exact temperature varying according to power loading. At least 30 minutes should be allowed between switch off and the commencement of work, and after this period, thorough checks should be made to ensure that all surfaces have cooled to a safe working temperature before work is started, and a further cooling period allowed if necessary.

CAUTION



The procedures below involve the handling of circuit boards containing components which are susceptible to damage caused by the discharge of static electricity. It is essential that suitable static handling procedures be established before work is started.

1.1 HAZARDOUS VOLTAGES

A full definition of 'Hazardous' voltages appears under 'Hazardous live' in BS EN61010. Briefly, under normal operating conditions, hazardous voltages are defined as being > 30 V RMS (42.2 V peak) or > 60 V dc.

	<p>invenys</p> <h1>Eurotherm</h1> <p>EUROTHERM LIMITED Faraday Close, Worthing, West Sussex, BN13 3PL Telephone: +44 (0)1903 268500; Fax: +44 (0)1903 265982 e-mail: info.uk@eurotherm.com Website: http://www.eurotherm.co.uk</p>
--	--

© Copyright Eurotherm Limited 2010
Specification subject to change without notice.
Invensys, Eurotherm, the Eurotherm logo, Chessell, EurothermSuite, Mini8, EPower, Eycon, Eyris nanodac and Wonderware are trademarks of Invensys plc, its subsidiaries and affiliates. All other brands may be trademarks of their respective owners.

2 DRIVER MODULE

For clarity of illustration, these procedures show the driver module removed from the panel. It is up to the user to decide whether this is necessary (depends on the nature of the work being carried out).

2.1 FITTING I/O, PREDICTIVE LOAD MANAGEMENT AND/OR COMMUNICATIONS MODULES

WARNINGS

1. Ensure that all hazardous voltages are isolated before starting work.
2. Check that the unit is at a safe temperature before starting work.
3. An isolation test must be carried out on the unit after re-assembly. Only units which have successfully passed such a test may be returned to service.

1. Open the door of the driver module.
2. Disconnect the existing connectors.
3. Remove the retaining plate by rotating the 1/4 turn fasteners (A in figure 2.1a) anti-clockwise (counterclockwise), and lifting the plate out.
4. This allows I/O and Communications modules to be inserted and/or removed as required.

Notes:

1. The modules must be inserted carefully, and pushed home firmly.
2. In order to prevent mis-matching of I/O modules, polarising pins and keys must be fitted as shown in section 5.2
3. The cover shown in figure 2.1b, is fitted only if there is no communications module fitted.

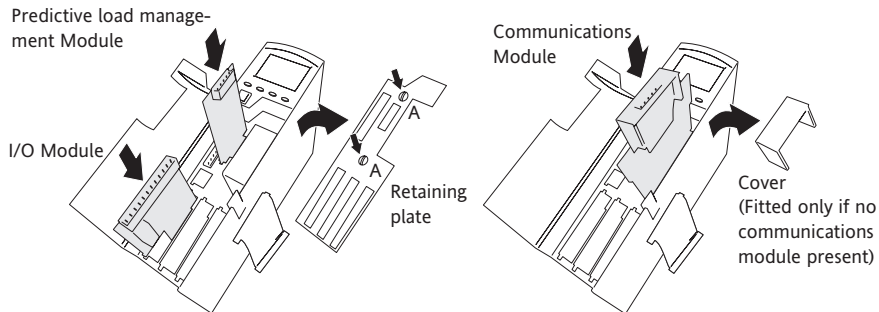

Figure 2.1a I/O Modules

Figure 2.1b Communications module

5. Once all the relevant modules have been inserted or removed, re-fit the retaining plate and secure by rotating the two 1/4 turn fasteners ('A') clockwise.
6. Reconnect the module connectors (or wire the modules as appropriate), and close the door. Re-configure the instrument, if necessary, and return to service.

5.2 I/O CONNECTOR DETAILS

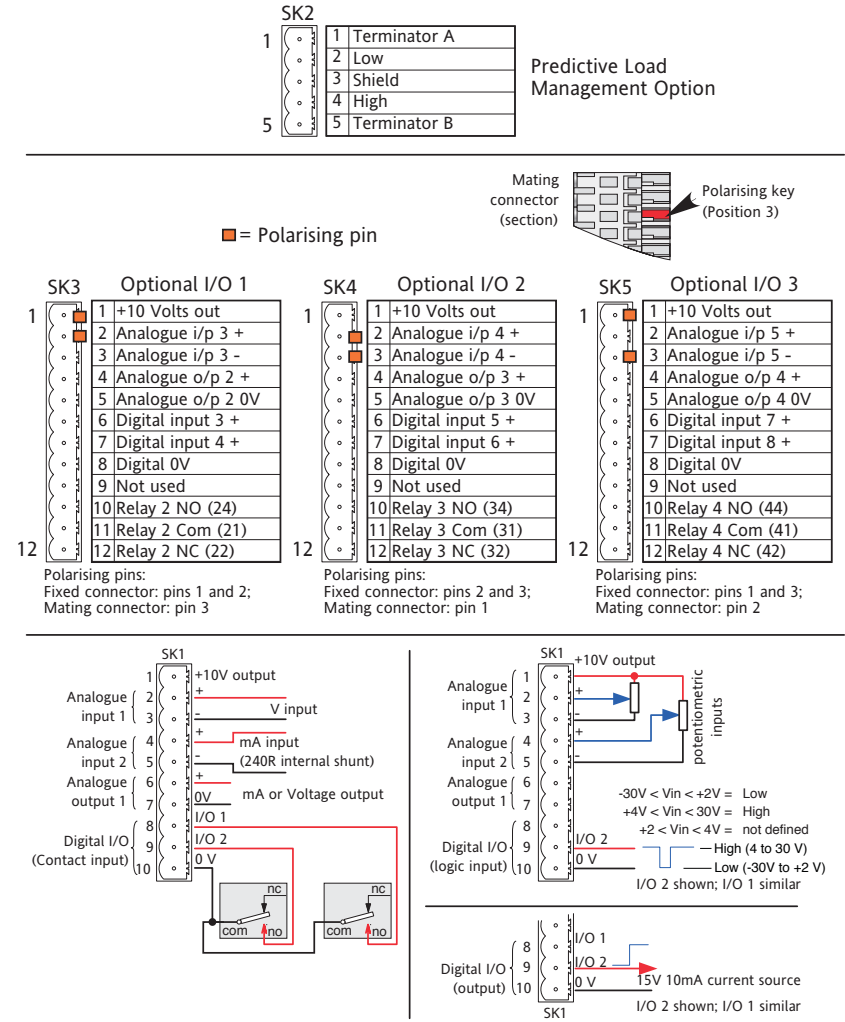

Figure 5.2 I/O connector pinouts and polarising details

Notes:

1. Analogue input/output types selected during software configuration.
2. Each analogue input -ve terminal is connected to 0V by an individual 150 Ohm resistor
3. Relay Com, NO and NC terms relate to the relay under power off (alarm) conditions.

5 REFERENCE

5.1 TORQUE SETTINGS

Table 5.1, below, shows torque settings for securing various items when reassembling the instrument.

Item	50/100/160A	250A	400A	500A	630A
Line/Load cable bolts/nuts	12.5Nm	25Nm	28.8Nm	30Nm	30Nm
Housing securing screws ('k' in fig 3.6b)	1.2Nm	1.2Nm	2.5Nm	2.5Nm	2.5Nm
Fuse securing bolts	12Nm	12Nm	15Nm	15Nm	15Nm
Thyristor securing bolts	2.5Nm	2.5Nm	5Nm	10Nm	12Nm
Snubber board securing bolts	2.5Nm	2.5Nm	10Nm	10Nm	12Nm
Safety Earth securing bolts	5Nm	12.5Nm	15Nm	25Nm	25Nm

Table 5.1 Torque settings

2.2 OTHER DRIVER UNIT ITEMS

The following is a general procedure dismantling the driver module. The user should follow the instructions as appropriate to the job in hand,

1. Disconnect the supply voltage and fan connectors (if fitted). Open the driver unit door and remove all connectors.
2. Remove the safety earth connection (B in figure 2.2).
3. Ensure that the relevant supply voltage is isolated. Open the door of the first power module and disconnect the ribbon cable that connects the drive unit to the power unit.
3. Whilst supporting the weight of the driver module, remove the two securing screws (C) and de-mount the driver module and move it to a static safe area.
5. Remove the mounting brackets (see note 1) by undoing the two screws (D) and sliding the brackets sideways to disengage the securing lugs (E).

Notes:

1. 500 Amp and 630 Amp modules have one bracket; all other modules have two - one at the top of the module, one at the bottom.
2. When re-assembling 50 Amp to 400 Amp units, ensure that the securing lugs (E) are located in the correct apertures, as indicated on the side of the module.

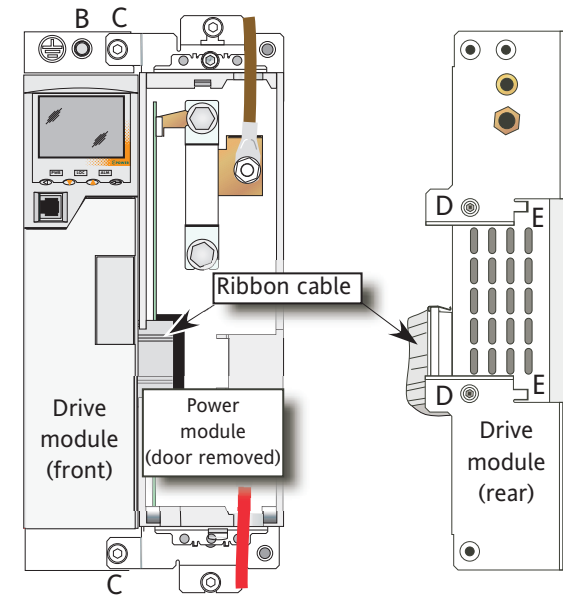

Figure 2.2 Drive module demounting
(100 Amp module shown - other modules similar)

2.2.1 Side cover removal

Remove the side cover by removing the plastic rivet assembly ('F' in figure 2.2.1) and sliding the cover away from the front housing.

When re-assembling, ensure that all catches are located in their apertures before using the rivet to secure the cover.

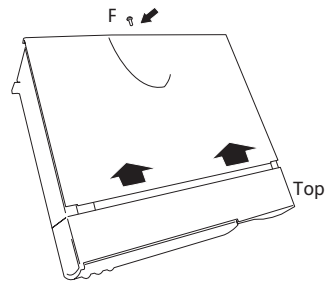

Figure 2.2.1 Cover removal

2.2.2 Front Housing removal

This describes the separation of the front housing (including the main circuit board) from the chassis

Use a screwdriver to release the plastic securing latches ('G' in figure 2.2.2a). The front housing can now be carefully separated from the chassis (figure 2.2.2b), disconnecting the (latched) power connector as it becomes accessible.

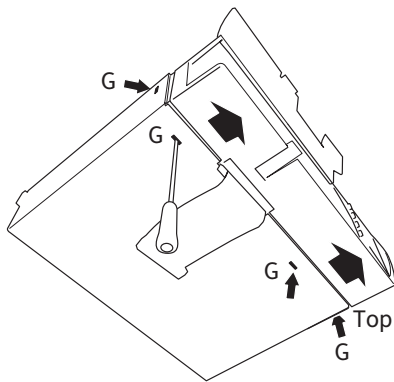

Figure 2.2.2a Securing latches

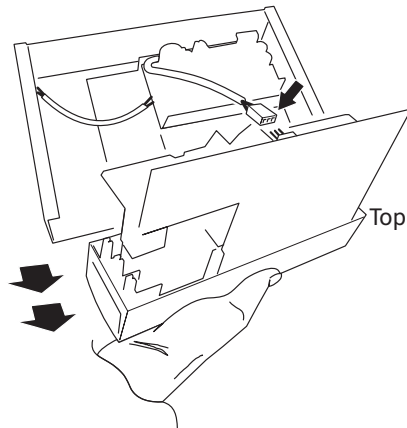

Figure 2.2.2b
Separate housing from chassis

4.5 CURRENT TRANSFORMER REPLACEMENT.

The current transformer can be replaced by removing its associated bus bar. The bus bar is secured by two M5 screws ('t' in figure 4.5) and the two load cable nuts (M12, 18.5mm A/F) which would normally already have been removed.

With the bus bar free, the current transformer can be slid off the bus bar, and a replacement fitted if required.

Notes:

1. The current transformer is a sliding fit onto the bus bar. When removing the bus bar, care should be taken not to allow the current transformer to slide off inadvertently.
2. When fitting a current transformer, ensure that it is oriented correctly otherwise the bus bar will not fit and/or the cable harness will be unable to reach its mating connector.
3. When reassembling, refer to table 5.1 for torque settings.

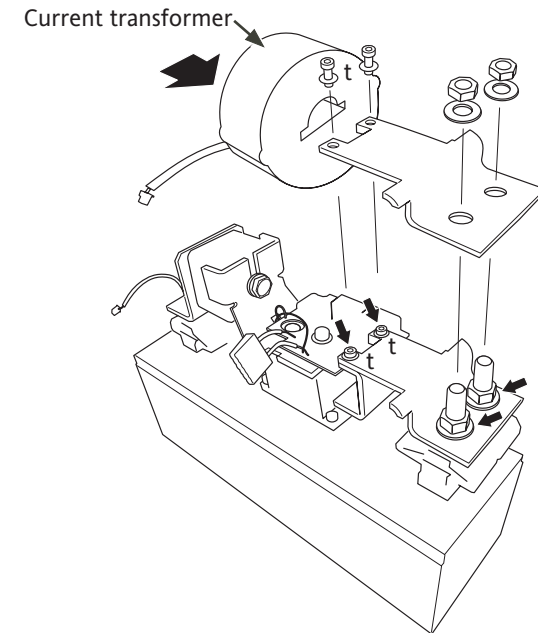

Figure 4.5 Current transformer replacement

4.3 SNUBBER BOARD REPLACEMENT

If the fuse is still fitted, remove securing bolt 'p' (figure 4.3).

Release the snubber board by undoing the three screws ('q' in figure 4.3). As they become accessible, remove the blue and green wire 'fast-on' connectors (r) from the thyristor.

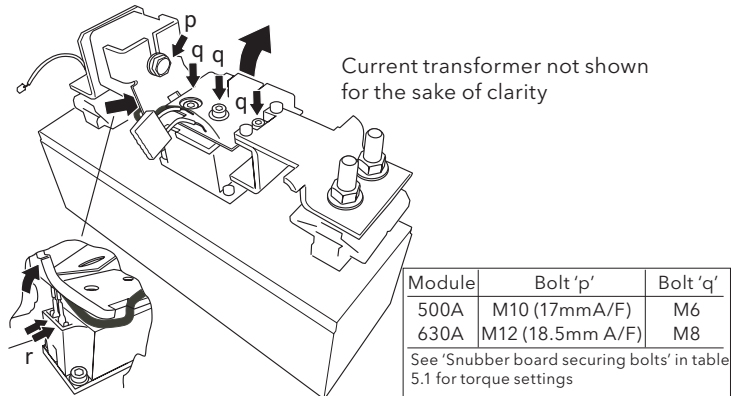

Figure 4.3 Snubber board removal

When reassembling:

1. Ensure that the green and blue wires (r) are connected to the correct thyristor terminal as shown in figure 3.3b.
2. Refer to table 5.1 for torque settings for securing screws, bolts etc.

4.4 THYRISTOR REPLACEMENT

With the snubber board removed, the thyristor unit becomes accessible, and it can be removed by undoing its four (M5) retaining screws ('s' in figure 4.4). When replacing the thyristor, ensure that a thin coating of heat-sink compound is applied evenly over the mounting surface. Refer to table 5.1 for torque settings.

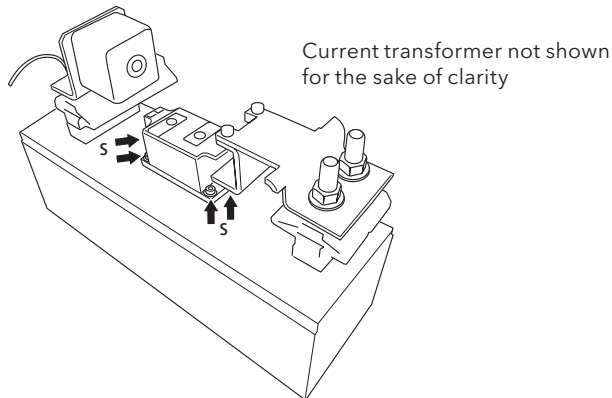

Figure 4.4 Thyristor replacement.

2.2.3 Ribbon cable replacement

The ribbon cable can now be removed, and replaced if required (Part number DN179917). The Connector is released by compressing the metal clips ('H') at the ends of the connector and pulling the ribbon cable part of the connector carefully away from the board mounted part.

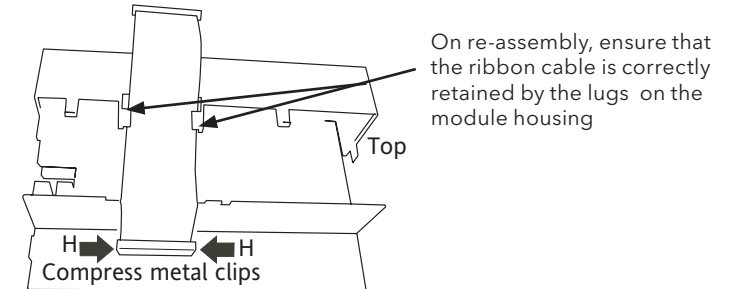

Figure 2.2.3 Ribbon cable

2.2.4 Main board replacement

1. For convenience, remove the ribbon cable, as described above, and any I/O or Communications options, and save them in a static safe environment.
2. Prise the securing rivets ('J') out of the board and place in a safe place for use in re-assembly.
3. The main board/cross board assembly can now be carefully removed, taking care not to damage the display board connector whilst doing so.

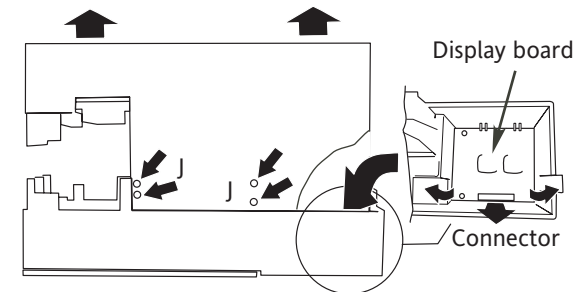

Figure 2.2.4 Main board removal

4. Fit the new board, taking care a) not to damage the display board connector during the process and b) that the connector is correctly mated.
5. Secure the new board using the plastic rivets previously removed.
6. Re-assemble the unit, and carry out an isolation test (section 2.3).

2.2.5 Power supply unit (PSU)

1. Disconnect the connectors 'K' associated with the connector board loom.
2. If the connector board is to be removed, undo the screw ('L' in figure 2.2.5) securing the connector board to the chassis. Keep the screw and its associated shake-proof washer in a safe place for use in re-assembly.
3. To remove the PSU, use a pair of pliers to compress the latching lug on each of the standoffs ('M') in turn. Ease each corner of the PSU board up as it is released, such that the relevant lug remains compressed by the circuit board whilst the other standoffs are worked on.
4. When all standoff lugs have been compressed, the PSU can be removed from the unit.
5. Fit the new PSU over the standoffs, ensuring that each lug retains its corner of the board.
6. Insert the connector board into its guide, such that the connectors emerge through the apertures in the chassis. Secure the board using the screw 'L' and shake-proof washer removed earlier.
7. Re-assemble the driver unit and carry out an isolation test (section 2.3).

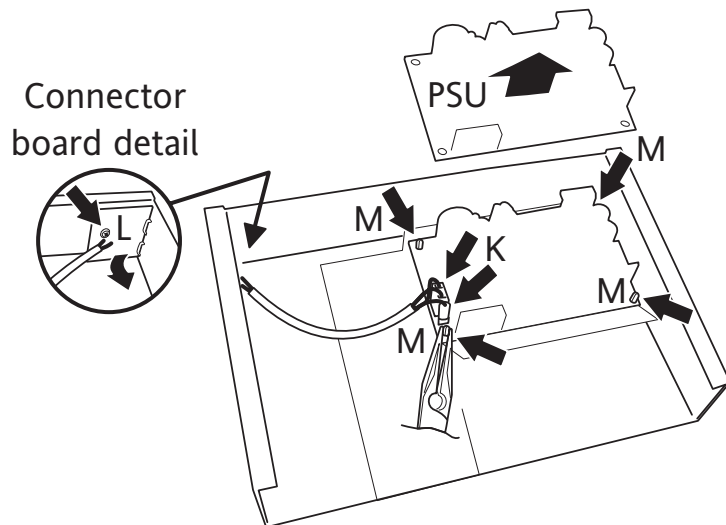

Figure 2.2.5 Power Supply Unit (PSU) removal

4 500AMP/630AMP MODULES

This section describes those parts which are unique to 500A/630A Power modules. Items not included here are either identical with the 400 Amp unit, or so similar that separate instruction is unnecessary.

The major differences are:

1. When removing the front cover, the cover does not rotate on spigots (as with other modules) but has to be slid downwards (once the retaining screws have been released) and away from the fixed part of the housing.
2. The supply and load cables are 'doubled up' so that there are two line and two load terminals, instead of just one.
3. The ribbon cable tray is extended in such a way that the plastic housing, of which it forms a part, must be removed first in order to gain access to the snubber board, current transformer and thyristor.

4.1 FRONT COVER REMOVAL

The front cover is removed by releasing the two 1/4-turn captive screws near the top, then gently pulling the top of the cover away from the unit whilst sliding the cover downwards out of its retaining lugs.

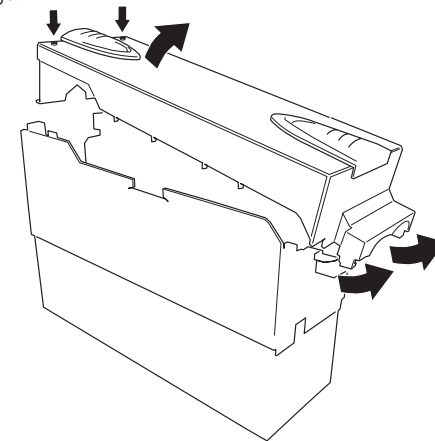

Figure 4.1 Cover removal

4.2 POWER BOARD REPLACEMENT

1. Remove the fan (if still fitted) as described in section 3.1. Disconnect both ribbon cables, and the snubber board and current transformer (if fitted) connectors.
2. The Power board and the Neutral/Phase reference boards can now be removed and replaced, as described for the 400A unit in steps 4 onwards of section 3.6.

3.7 CONVERSION TO EXTERNAL FEEDBACK

The following steps are necessary in order to convert from internal feedback (internal current transformer) to external feedback.

1. Remove the internal current transformer (sections 3.4, 4.5). (If this is left in place, some kV will be generated across the current transformer's flying lead connector during operation.)
2. Replace the power board and (for 250A/400A/500A/630A modules) the Neutral/Phase reference connector board, with a version suitable to receive inputs from external load voltage and load current measurement sources (sections 3.6, 4.2).
3. Before the replacement is fitted it is necessary to create apertures in the housing to accommodate the voltage and current feedback connectors. This is done by 'breaking out' the relevant areas of the housing, as shown in figure 3.7, below. A pair of side cutters is an appropriate tool (as shown).
4. Polarising pins and keys must be fitted (section 5.3) to ensure that the feedback signals are connected to the correct power module.

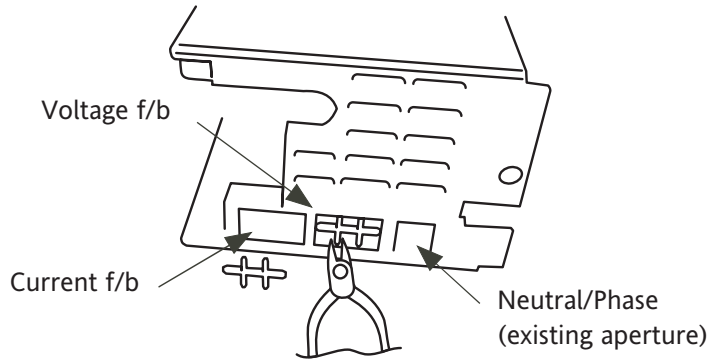

Figure 3.7 External feedback connector apertures

2.3 ISOLATION TEST

Isolation tests must be applied to the Driver and Power modules after reassembly. Only those modules which successfully complete these tests may be returned to operation.

An Earth Bond safety check must also be carried out for power modules. Only those modules which successfully complete these tests may be returned to operation.

2.3.1 Driver module isolation test

Driver module test groups:

SELV: Ribbon cable, Standard I/O, Option I/O, Configuration port

Comms: remote panel communications, Load management, Communications ports

Relay 1: Driver module relay 1

Relay 2: Optional I/O Module relay

Relay 5: Watchdog relay

Mains: Driver module supply voltage input

Earth: Driver module case

Test voltage applied for two seconds and discharged after test. Trip level 100µV

Tests:

Test No.	DC Test Voltage	Test group	Reference groups
1	0.9 kV	SELV	All others connected together
2	0.9 kV	Comms	All others connected together
3	3.0 kV	Relay 1	All others connected together
4	3.0 kV	Relay 2	All others connected together
5	3.0 kV	Relay 5	All others connected together
6	2.0 kV	Mains	All others connected together

2.3.2 Power Module Isolation test

Power module test groups:

Control: Ribbon cable, all connections

Power: Line, Load, Neutral

Vext: External voltage feedback VFA,VFB

Iext: External current S1, S2

Earth: Heatsink, earth.

Test voltage applied for two seconds and discharged after test. Trip level 100µV

Tests:

Test No.	DC Test Voltage	Test group	Reference groups
1	0.9 kV	Control	All others connected together
2	4.3 kV	Power	All others connected together
3	4.3 kV	Vext	All others connected together
4	4.3 kV	Iext	All others connected together

2.3.3 Earth Safety Bond Test

A test between the safety earth terminal and any metal part which is accessible to the user during normal operation.

A current of 25 Amps to be passed for 1 minute. Impedance must be less than 0.1 Ohm.

3 POWER MODULES

Note: See section 4 for details that are unique to 500A/630A power modules.

For clarity of illustration, these procedures show the modules removed from the panel. It is up to the user to decide whether this is necessary (depends on the nature of the work being carried out).

WARNINGS

1. Ensure that all hazardous voltages are isolated before starting work.
2. Check that the unit is at a safe temperature before starting work.
3. An isolation test must be carried out on the unit after re-assembly. Only units which have successfully passed such a test may be returned to service.

Note: Except where indicated otherwise, the illustrations in this document show the 400A unit.

3.1 FAN REPLACEMENT

The cooling fans are secured to the underside of the units by a single cap-headed screw ('a' in figure 3.1). Once this has been unscrewed a few turns, the fan cassette can be swung down, disconnected from adjacent fans, and lifted away from the module.

If the relevant fan is associated with the 'first' power module (that is the module next to the driver module) the loom from this fan to the drive module should first be disconnected at the fan end.

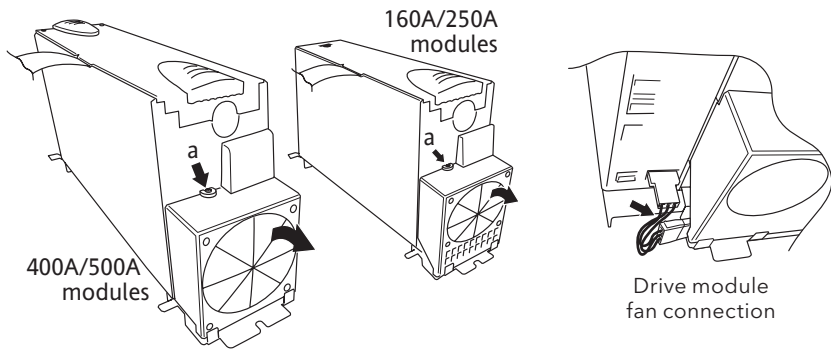

Figure 3.1 Fan removal

Fitting a replacement fan cassette is the reverse of the above procedure.

3.6 POWER BOARD REPLACEMENT (CONT.)

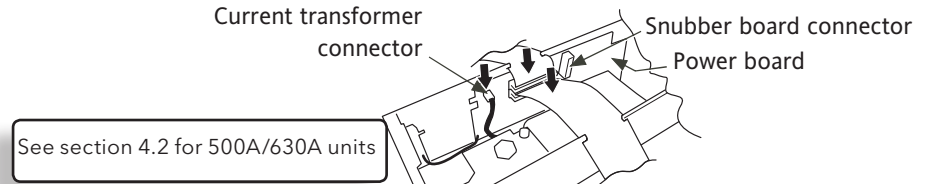

Figure 3.6a
Disconnect ribbon cables, snubber board and current transformer connectors.

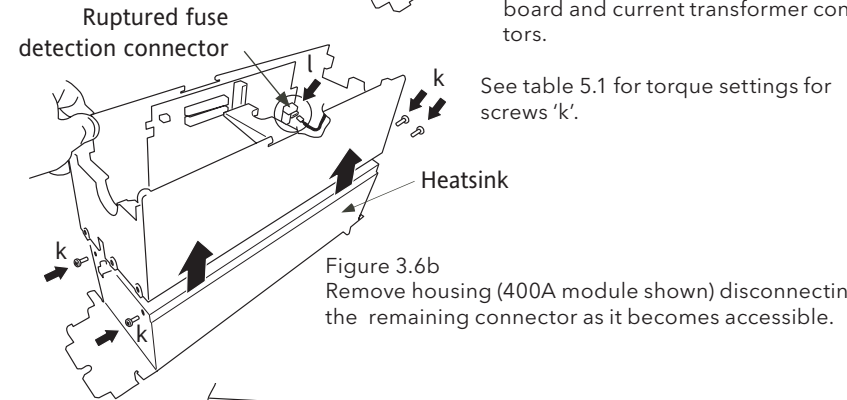

Figure 3.6b
Remove housing (400A module shown) disconnecting the remaining connector as it becomes accessible.

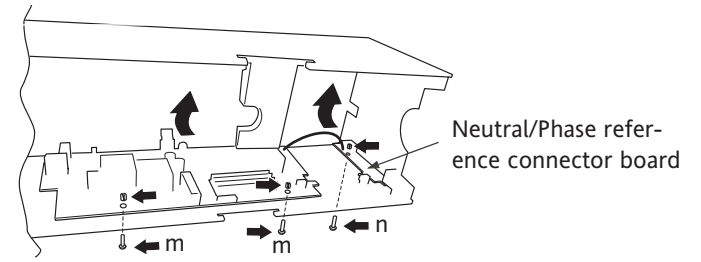

Figure 3.6c Remove power board (250A/400A units)

When re-assembling, ensure that the power circuit board and the Neutral/Phase reference connector board are located in the retaining slot which runs down the length of the aluminium heat sink near its left-hand edge.

Ensure that the retaining lug (figure 3.6d) of the Neutral/Phase-reference connector board is correctly located before securing the board with the plastic rivet.

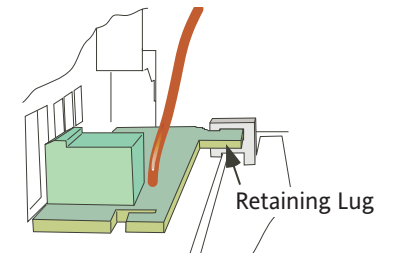

Figure 3.6d Neutral/Phase-reference connector board detail

3.5 THYRISTOR REPLACEMENT

This requires the prior removal of the fuse, the snubber board and the current transformer, as detailed in previous sections.

1. Remove the fuse bus bar by undoing the securing screw ('i' in figure 3.5).
2. The thyristor can now be removed, by undoing its securing screws ('j'). When fitting the replacement, ensure that a thin coating of heat-sink compound is applied evenly over the mounting face of the new thyristor.

See section 4.4 for 500A/630A units

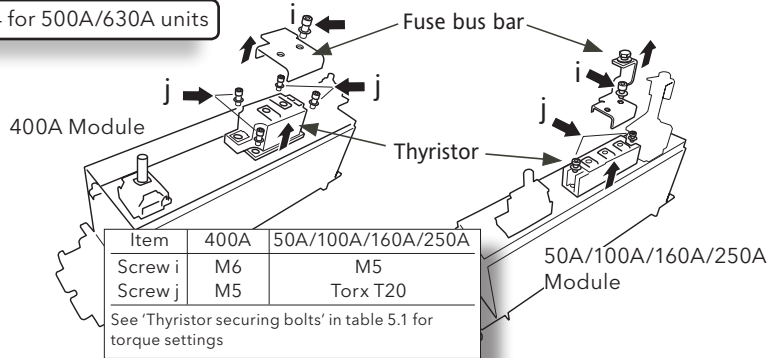

Figure 3.5 Thyristor removal (see section 4.4 for 500A/630A modules)

3. Re-assembly is the reverse of the disassembly procedure followed so far. Ensure when re-fitting the current transformer, that it is oriented correctly as shown in figure 3.4, and that the harness is retained by the plastic retaining loop attached to the power board.
4. An isolation test (section 2.3) must be carried out on the unit after reassembly. Only units which have successfully passed such as test may be returned to normal service.

3.6 POWER BOARD REPLACEMENT

The following procedure describes the 400A unit. Other units are similar, the major difference being that the small circuit board that holds the reference voltage connector (and, if the external feedback option is fitted, the feedback connectors) is an integral part of the power board for 50A, 100A and 160A modules, but is a separate board for higher current Modules.

1. Remove the fan cassette (if fitted) as described in section 3.1.
2. Open the cover, as described in section 3.2.
3. Disconnect both ribbon cables and the snubber board and current transformer connectors (figure 3.6a).
4. Undo the housing retaining screws ('k' in figure 3.6b). (The figure shows a 400A unit; other units are similar, but have only two securing screws).
5. Lift the housing away from the chassis, disconnecting the fuse rupture detector connector ('l' in figure 3.6b) as it becomes accessible.
6. With the housing free from the chassis, the power board can be removed by releasing the plastic rivets ('m' in figure 3.6c) securing it to the housing, and for 250A and 400A modules, the plastic rivet ('n') securing the Neutral/Phase reference connector board.

3.2 FUSE REPLACEMENT

After ensuring that the module is isolated from all hazardous voltages, release the front cover, as shown in figure 3.2a.

The 50A, 100A, 160A and 250A module covers are released by inserting a non-insulated screwdriver with a 1/4 inch or 5 mm blade into the aperture near to top of the cover, and pulling down on the screwdriver handle to release the catch.

The 400A unit cover is secured by two 1/4 turn captive screws ('b'), which when undone, allow the door to be opened and lifted off its retaining lugs. See section 4.1 for 500A/630A Modules.

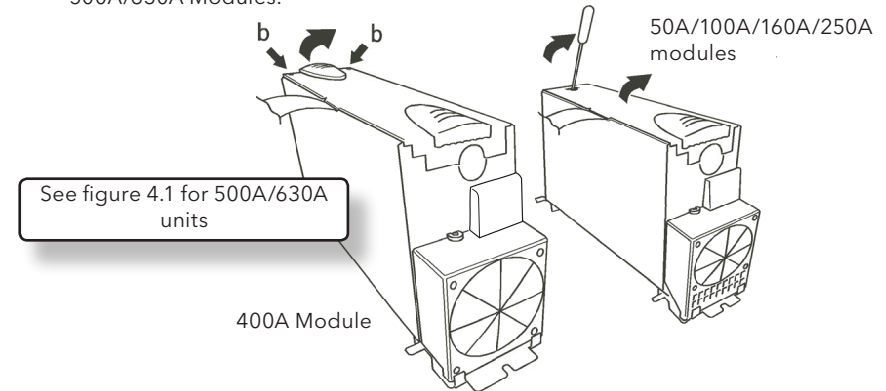

Figure 3.2a Opening the module cover

With the cover removed, the content of the module is revealed, including the fuse. To remove the fuse, undo the retaining bolts ('c') sufficiently to allow the fuse to be removed (figure 3.2b). The fuse may now be replaced, using the previous fixings, ensuring that the vibration-proof washers are correctly positioned between the bolt head and the fuse.

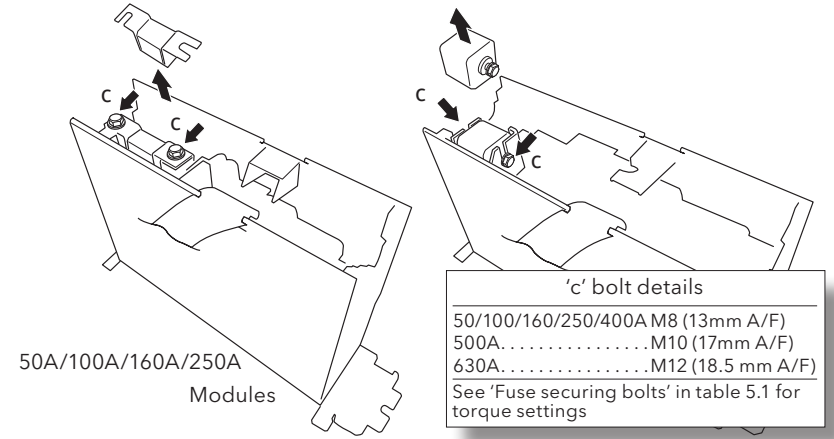

Figure 3.2b Fuse removal

3.3 SNUBBER BOARD REPLACEMENT

In addition to its own replacement, the snubber board must also be removed in order to replace the thyristor and/or to replace the current transformer.

Note: the snubber board is connected to the thyristor by two wires (blue and green) using push-on connectors. There are four terminals on the thyristor. The green and blue wires must be connected to the correct thyristor terminal, or the thyristor will not fire correctly and power will not be controlled. One of two types of thyristor may be supplied as a spare, which might or might not be of the same type as the existing thyristor. Figure 3.3b, below shows connection details for both types.

1. If not already removed, remove the ribbon cable which crosses from the power board to the right-hand side of the unit.
2. Disconnect the large connector ('f' in figure 3.3a) connecting the snubber board to the main power board.
3. Disconnect the two wires ('e') from the snubber board to the thyristor, noting to which of the four terminals each wire of the replacement board must be connected.
4. Undo and remove the two securing bolts ('d') taking care that the shake-proof washers are retained. The bolts are 5mm caphead for 50A, 100A, 160A and 250A modules, or 6mm caphead for 400A modules).
5. The snubber board can now be removed.
6. When re-assembling, see table 5.1 for torque settings.

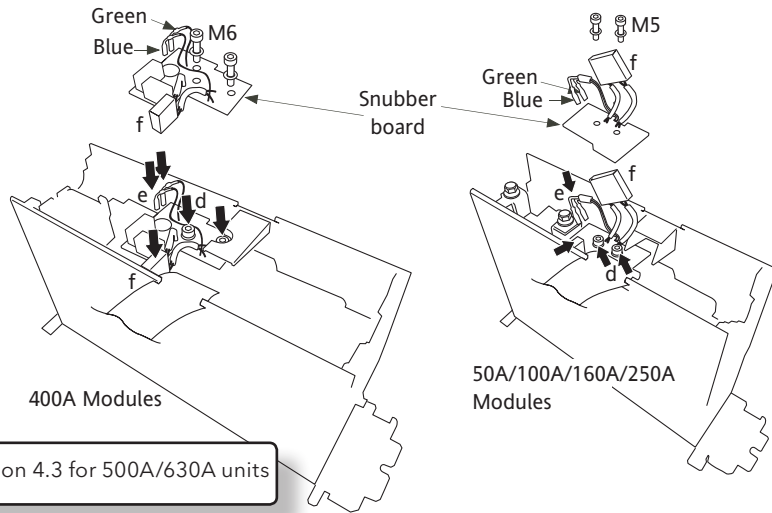

Figure 3.3a Snubber board replacement

3.3 SNUBBER BOARD REPLACEMENT (Cont.)

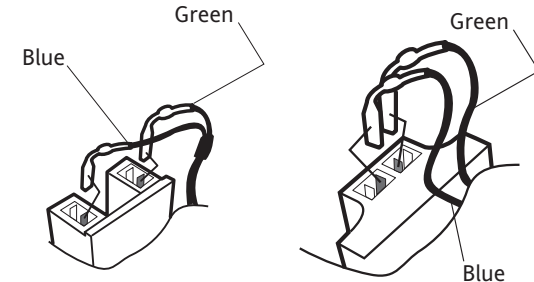

Figure 3.3b Thyristor terminal connection detail

3.4 CURRENT TRANSFORMER REPLACEMENT

With the snubber board removed, access can be gained to the current transformer.

Notes:

1. The current transformer is a sliding fit onto the same bus bar that provides load termination. When removing the bus bar, care should be taken not to allow the current transformer to slide off inadvertently.
2. For the 50A, 100A, 160A and 250A modules, the same nut is used to terminate the load as is used to secure the bus bar. For the 400A module, the fixings are separate but the load cable must first be removed in order to access the bus bar securing nut.
3. When fitting a current transformer, ensure that it is oriented correctly, or its busbar will not fit when re-assembly is attempted.

1. Disconnect the flying-lead connector ('g' in figure 3.4) from the power board.
2. Undo the M8 or M10 securing nut ('h') and lift the bus bar and current transformer out of the chassis. The Current transformer can now be slid off the bus bar and replaced if required.

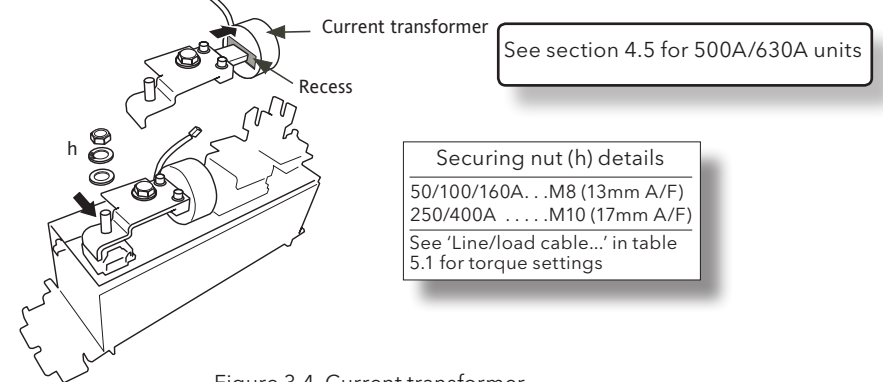

Figure 3.4 Current transformer (400A module shown; other modules similar but see section 4.5 for 500A/630A modules)